



WEBSTER

SINCE 1876

INSTALLATION OPERATION & MAINTENANCE INSTRUCTIONS NO. 500078

Model FSL Vibrating Conveyor with P3000 Drive
Model FSM Vibrating Conveyor with P5000 Drive

websterchain.com • 800.243.9327

ISO9001 Registered

Table of Contents

DESCRIPTION.....	2
FOUNDATIONS OR SUPPORTS	2
CONVEYOR INSTALLATION INSTRUCTIONS.....	4
DRIVE INSTALLATION AND TIMING INSTRUCTIONS.....	4
OPERATION.....	5
CONVEYOR MAINTENANCE.....	5
LUBRICATION	5
DRIVE MAINTENANCE.....	8
DRIVE ASSEMBLY INSTRUCTIONS	9
TROUBLE SHOOTING	12
I. Conveyor won't start.....	12
II. Conveyor is noisy	12
III. Drive bearings are hot.....	12
IV. Drive seems to slip out of time.....	12
V. Spring bolts are breaking	12
VI. Clamp block bolts breaking	12
VII. Pan flange bolts breaking.....	13
VIII. Breakage of infeed spouts on chipper or hog infeed conveyors	13

DESCRIPTION

The Webster Model FSL and FSM vibrating conveyors are positively driven mechanical vibrating conveyors. These are unbalanced machines and therefore require substantial foundations.

The conveyor (see sketch on page 7) consists of a pan or trough supported by flat springs from a stationary base. Vibration is imparted to the pan by the drive, which in turn is driven by a standard electric motor. Most of the power required to vibrate the empty pan is alternately stored and released by the springs, while the motor supplies the remainder plus the power required to overcome friction in the drive and to convey material.

The P3000 and P5000 drives (see illustration on page 12 and 13) are of the positive, eccentric type and are designed for continuous operation under severe conditions. The pillow blocks and the lower end of the connecting rod are equipped with self-aligning roller bearings. The upper end of the connecting rod is equipped with a rubber bushing which accommodates misalignment and eliminates the need for lubrication at this point.

FOUNDATIONS OR SUPPORTS

In an unbalanced vibrating conveyor the inertia force produced by the vibration of the empty pan and the force required to convey material are transmitted through the foundation and into the earth below. To prevent damage to the conveyor, the foundation, and to nearby equipment or structures because of vibration or settling, the foundation must have sufficient stiffness and mass and the soil conditions must be such that the natural frequency of the foundation on the soil is at least two times the operating frequency of the conveyor. For most installations at or below ground level where the foundation is on a stable soil having high bearing value, foundations as shown on page 3 have proven to be adequate. This type of foundation should be continuous and preferably should be integral with the surrounding floor or structure. Concrete thickness and widths are based on standard conveyors 12" wide x 10 gauge pan thickness for the 6" base channel, and 18" and 24" wide x 3/16" thick pans for the 13" wide base channel. Pans of different width or thickness, or op-

tions such as liners, covers, or screen decks may require more concrete mass than shown.

Foundations should be on undisturbed soil, if the soil has been disturbed or fill is necessary, it should be tamped to 95% or greater compaction. Foundations should never rest partly on soil and partly on rock or on two very different types of soils. Foundations should be continuous for any single conveyor and should be well reinforced. If the foundation is to be on a soft or unstable soil such as sand, gravel, soft clay or is high in organic matter or if water table is near the surface, serious foundation vibration and/or settling problems can occur. Because these problems are due to soil conditions over which it has no control, Webster Industries, Inc. can assume no responsibility for them. If such soil conditions exist or are suspected, or if problems have been experienced with other types of vibrating or reciprocating machinery, it is recommended that the customer consult an engineering firm which specializes in soils and foundations.

If water is permitted to work its way into the soil under the conveyor foundation, it will soften the soil, and this may result in serious vibration and/or settling. If the foundation is exposed to the weather, any excavation around it should be backfilled, the soil compacted and the area graded as soon as possible to prevent the accumulation of water. If the conveyor is to be installed inside on a floor and there is a possibility of water draining onto the floor, adequate drainage should be provided to prevent water from accumulating and seeping through any cracks or expansion joints which may exist.

The preferred method of attaching the conveyor to its foundation is to weld it to beams which are imbedded in the concrete as shown in the sketch on the top of page 3. These beams should be continuous over the full length of the conveyor base. If anchor bolts are to be used, they should be cast in place, set in a non-shrink grout or resin-capsule type anchor bolts should be used, do not use expansion shields. Anchor bolts should be equipped with either double nuts or self-locking nuts. The latter are preferred as they facilitate periodic retightening. Metal shims of the size shown on page 3 should be used between the anchor bolt pads and the foundation, do not use grout.

If a vibrating conveyor is to be installed over a pit or on a low structure, special attention must be given to the design

**CONVEYORS WITH 6' WIDE BASE CHANNEL
(12' WIDE x 10 GAUGE THICK PANS)**

**CONVEYORS WITH 13' WIDE BASE CHANNEL
(18' AND 24' WIDE x 3/16 THICK PANS)**

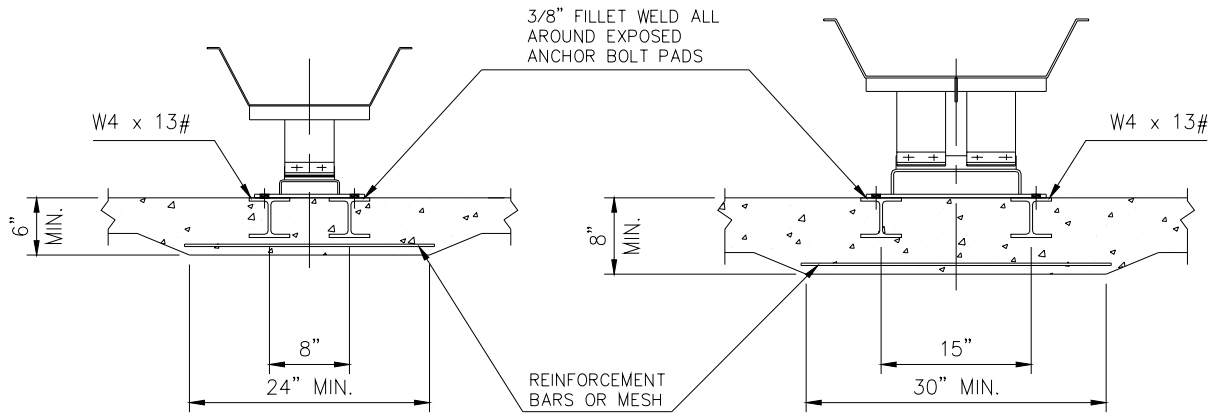

FOUNDATIONS WITH STEEL BEAMS EMBEDDED IN CONCRETE

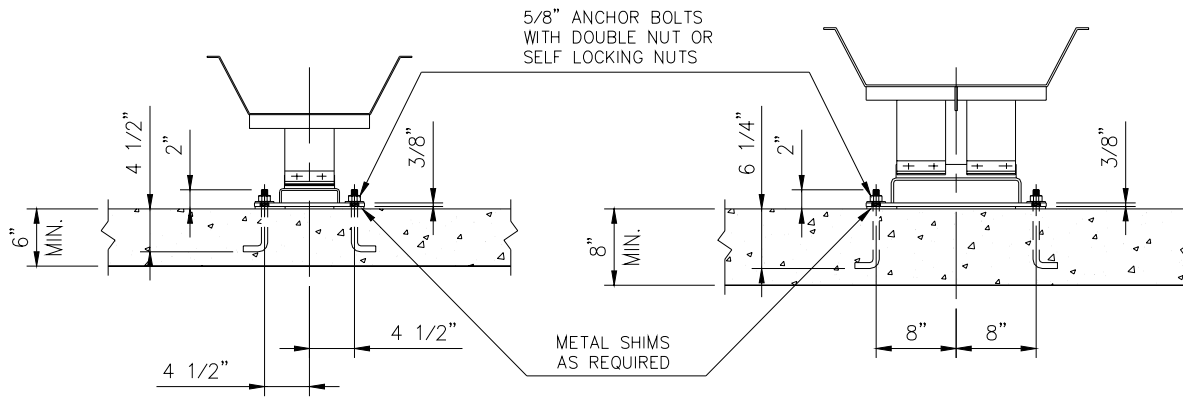

FOUNDATIONS WITH ANCHOR BOLTS IN CONCRETE

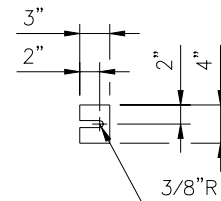

RECOMMENDED SHIM SIZE

FOUNDATIONS FOR MODEL FSL AND FSM VIBRATING CONVEYORS

of the supports. The supports must be strong enough to support the conveyor and to transmit the unbalanced forces. In addition, the natural frequency of the structure both horizontally and vertically must be at least twice the operating frequency of the conveyor.

Relatively short (up to 40 feet long) conveyors may be equipped with an inertia base and vibration isolation springs to reduce the forces transmitted to the supporting structure. The beams or floor which supports the conveyor, again, should have a natural frequency at least twice the operating frequency of the conveyor. The weight of the beams or floor and of any other equipment supported by them should be included when calculating this natural frequency. Generally the supporting beams or floor will be much heavier than is required to support the static weight of the conveyor.

CONVEYOR INSTALLATION INSTRUCTIONS

The conveyor should be installed so that it is accessible for inspection and maintenance. One side should be accessible full length, and both sides should be accessible at the drive. We recommend that a minimum of 2" of clearance be maintained between the vibrating pan and any adjacent surface.

When handling the conveyor sections during unloading and installation, use care to avoid damage. Lift the conveyor sections by their pans, if slings are used, use spreaders in the slings to avoid crushing the pan, and be certain that the slings do not contact the springs. When installing the conveyor, shim as necessary between the floor and the anchor bolt pads at each end of the base until the pan is level crosswise and either level or at the desired slope lengthwise, then shim between the floor and the intermediate anchor bolt pads **DO NOT PULL THE BASE CHANNELS DOWN TO THE FLOOR**. If the conveyor is shipped in more than one section, install the section having the drive first. Place the other sections so the flanged pan joints mate, starting with the bottom corners, level, and then align the sides. Tighten bolts in the following sequence: First - bolts in pan flanges; Second - anchor bolts; and Third - bolts in the base channel splices. Be certain that the flanged pan joints butt so the springs are not strained out of line when the pans are bolted together.

After installation is complete, but before operating the conveyor, check the timing of the drive, and, if necessary, retime as outlined on page 5. Be certain to remove the timing pin

before attempting to operate the conveyor. The direction of rotation on the eccentric shaft does not effect the operation of the conveyor. The same is true for the operation of most three phase motors (see connection diagram for specifications). Check all bolts and nuts for tightness, tightening torques for all critical fasteners are given in the sketches on pages 7 and 8. After the first sixteen hours of operation, all bolts should again be tightened. During the first 8 to 16 hours of operation a large amount of grease will be thrown from the bearing seals, and the bearings will operate at an elevated temperature. After this break-in period, the grease release will slow to a slight purge at the seals, and the operating temperature of the bearing housings should decrease to their normal operating temperature range.

Stationary chutes, skirts, hoppers, etc. must not strike or rub the pan or springs. Any connection to the pan must be flexible. Do not add any substantial amount of weight to the pan or make any structural alterations to the machine without first consulting the factory.

DRIVE INSTALLATION AND TIMING INSTRUCTIONS

(See illustration on pages 7 and 8)

The timing of a vibrating conveyor is achieved by setting the eccentric drive in the neutral position, at the same time the spring system is at rest with no load in the pan, the spring system's neutral position.

1. Install the shims (item 1) and the drive (item 2) in the conveyor and loosely assemble items 3 through 7 as shown.
2. Center the connecting rod between the clamp blocks (item 6) at the upper end. The clearance between the connecting rod seal carrier and the eccentric shaft should be even all around, check with a .015" thick feeler gauge. This may be corrected by shifting the upper end of the connecting rod toward one side of the conveyor and removing one or more shims from under the pillow block and installing them under the pillow block on the opposite side.
3. The pillow block housing must be square with the eccentric shaft so the groove between the housing and the seal ring is even all around, this may be checked visually. If necessary, correct by pivoting the housing.
4. The timing bracket (item 3) should be installed on the side opposite the sheave. The bracket must be assembled so a hole for the timing pin is up and toward the feed end

of the conveyor. (See sketches on page 7 and 8) Insert the timing pin through this hole in the bracket, and rotate the eccentric shaft until the pin enters the keyway in the shaft. Tighten the bolts (item 7) which clamp the blocks (item 6) to the drive bracket. Tighten the pillow block hold-down bolts (item 4) and the set screws (item 5) and remove the timing pin from the timing bracket.

5. The timing of the drive should be checked when the conveyor is stationary and the pan is free of burden, be certain that there is no build-up of material under the pan. To check the timing, rock the eccentric shaft several times by pulling on the rim of the sheave, allow it to come to rest and insert the timing pin through the hole of the timing bracket. If the pin does not come within one pin diameter of entering the keyway in the eccentric shaft, the power unit should be retimed. If the keyway is 180 degrees or one half of revolution away from the hole in the timing bracket, rotate the shaft 180 degrees before checking the timing. **CAUTION – BE CERTAIN THAT THE DRIVE HAS NOT STOPPED IN DEAD CENTER BEFORE ATTEMPTING TO ROCK THE ECCENTRIC SHAFT.**

6. To retime the drive, loosen the bolts (item 7) in the clamp blocks, insert the timing pin through the hole in the timing bracket, rotate the shaft until the pin enters the keyway in the shaft, tighten the bolts in the clamp blocks and remove the timing pin. Note: When rotating the shaft the pan must not move, if the shaft cannot be rotated enough so the pin will enter the keyway it may be necessary to loosen the pillow bolts (item 4) and the setscrews (item 5) and move the pillow blocks.

OPERATION

Do not allow a build-up of sticky material to remain in the pan. This additional vibrating weight will cause excessive loads on the drive and, if great enough, may cause serious structural failure.

Avoid heavy bin or hopper loads. They cause excessive loads on the drive and the driving motor, and they may tend to buckle the springs.

If the conveyor is equipped with covers or a secondary pan, some means of controlling the feed should be employed to avoid lugging or choking.

Do not allow material to accumulate around the conveyor. A build-up of material around the springs will abrade them

causing failure. A build-up of material around the drive may bury the pillow blocks causing them to overheat and seize, material may work into the bearings and thus cause failure, or the material may abrade the belts and sheaves. Do not allow any skirts, chutes, hoppers, etc. to strike or rub against the pans or springs. Consult the factory before adding any substantial amount of weight to the pan, making any structural alterations, or changing the operating frequency of the conveyor.

CONVEYOR MAINTENANCE

The conveyor is an inherently quiet running machine. It should be operated periodically while empty and while adjacent equipment is shut off, any noises heard should be investigated and the trouble remedied.

Check the timing of the drive when it is lubricated and re-time, if necessary.

Keep all bolts tight, this is especially important for the bolts which clamp the ends of the springs, those which attach the drive to the drive bracket and to the base, and the anchor bolts. Tightening torques for the all critical fasteners are given on pages 7 and 8.

Periodically inspect the springs and replace any that are damaged or broken. If a spring pad is to be replaced, use the springs to locate the new pad, tack weld the pad in place

WARNING

**Never operate Machine with Guards Removed
Disconnect and Lockout Power Before Removing Guards to Service Equipment**

and then remove the springs so they are not damaged by the heat from welding. Handle springs carefully to avoid damage. Spring pads and clamps must be smooth and flat, and shims must be used between springs and clamps and between springs and pads. See sketches on page 8. Seal the joints between springs and the clamps and pads at the lower end of the springs with a non-hardening sealer. Use only replacement springs obtained from the factory.

LUBRICATION

The only parts of the conveyor requiring lubrication are the two pillow blocks and the center bearing of the drive. These points are equipped with hydraulic type lubrication fittings.

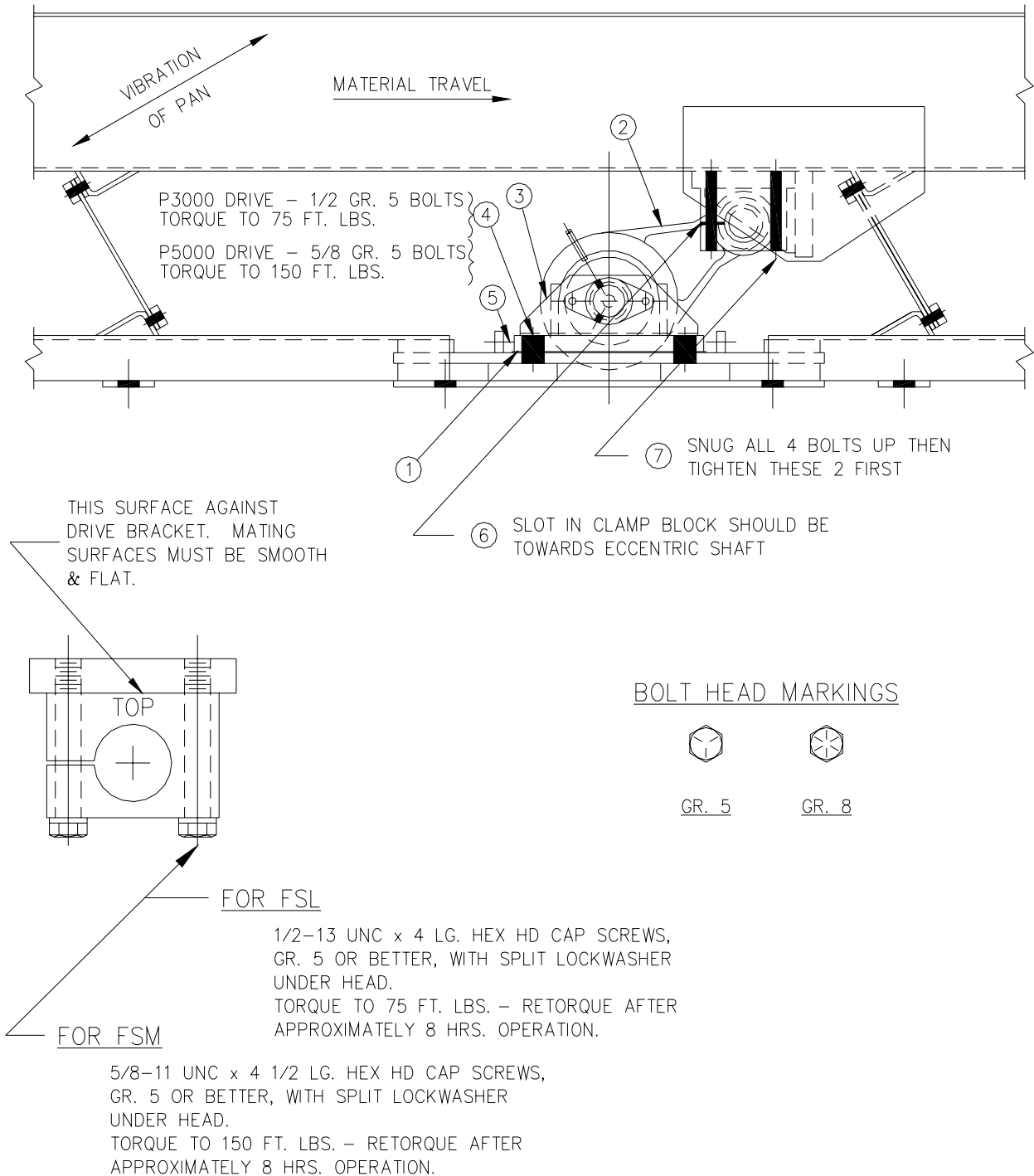

DRIVE INSTALLATION

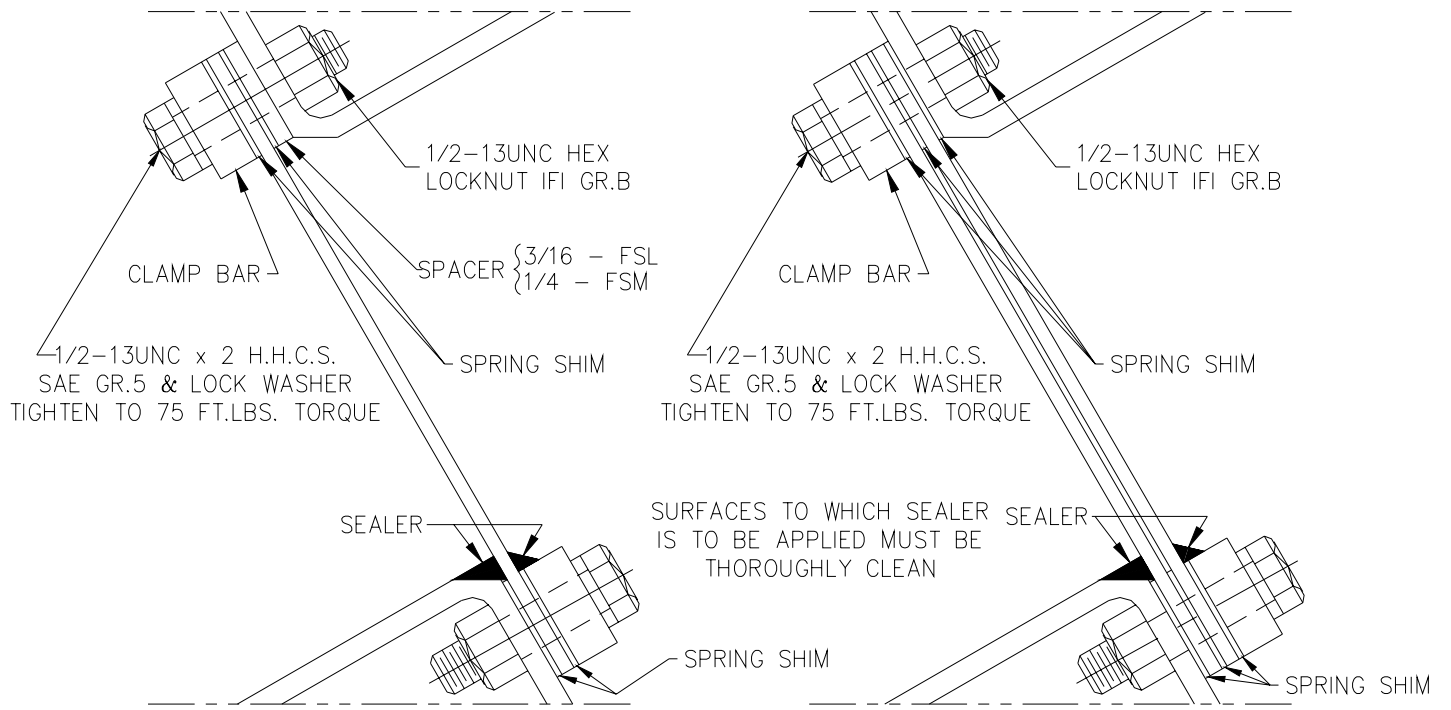

SPRING STACK W/1 LAYER OF SPRINGS SPRING STACK W/2 LAYERS OF SPRINGS

SPRING INSTALLATION

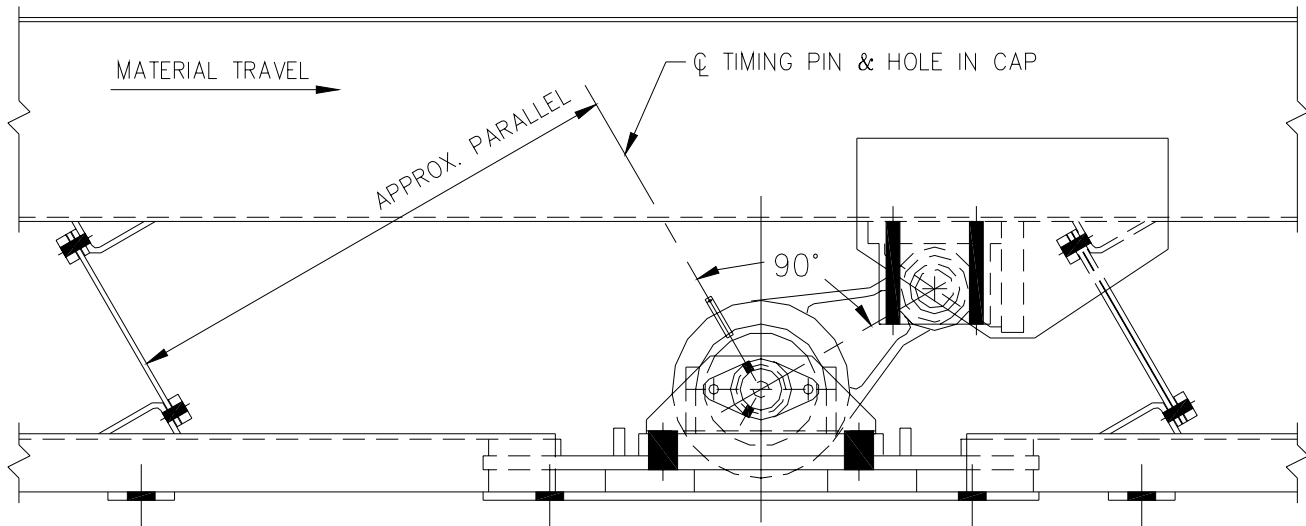

NOTE: THE TIMING BRACKET IS INSTALLED ON THE SIDE OF THE CONVEYOR OPPOSITE THE V-BELT DRIVE. THE BRACKET MUST BE ASSEMBLED SO A HOLE FOR THE TIMING PIN IS UP AND TOWARDS THE INFEED END OF THE CONVEYOR. THERE ARE TWO HOLES IN THE CAP, 60° ABOVE AND BELOW THE HORIZONTAL CENTERLINE. IF THE TIMING BRACKET IS TO BE MOVED TO THE OPPOSITE SIDE OF THE CONVEYOR, THE CAP MUST BE ROTATED 180° OR 1/2 TURN ABOUT THE SHAFT CENTERLINE TO GET A HOLE IN THE PROPER LOCATION.

INSTALLATION OF TIMING BRACKET

With seals of the type used in P3000 and P5000 drives, the grease in the bearing housings not only lubricates the bearings but also helps prevent the entry of foreign material into the housings. It is therefore necessary to add grease to the bearings more frequently and in greater quantity than if the grease served only as a lubricant and since the bearing housings are almost filled with grease, the bearings operate at a relatively high temperature.

For safety, the bearings should be lubricated while the conveyor is stationary. They should be lubricated when at their normal operating temperature. Grease should be pumped in until it starts to work out through the seals, and then the conveyor should be operated for at least one hour to allow excess grease to work out through the seals, this is particularly important in cold weather, as cold bearings completely filled with cold grease will require excessive power to start and operate and may overload the driving motor.

For a short period immediately after lubrication grease will be thrown from the bearings, and thereafter a slight showing of grease around the bearing seals is normal. When grease no longer shows around the seals it is time to relubricate. The following lubrication periods are given only as a guide for operation under relatively clean conditions. For extremely dusty or dirty conditions it will be necessary to lubricate more frequently.

HOURS OF OPERATION PER DAY	LUBRICATION PERIOD-WEEKS
8	8
16	4
24	2

A high quality, high temperature grease made for use in roller bearings should be used. It should be smooth, non-fibrous, free of chemically or mechanically active ingredients, and its melting point should be considerably higher than the operating temperature of the bearings. For most conditions a lithium or soda base grease of medium (NLGI Number 2) consistency should be satisfactory. Extreme pressure (EP) greases are particularly recommended. For unusual conditions consult a lubrication engineer from a reputable oil company.

DRIVE MAINTENANCE

The P3000 and P5000 drives are inherently quiet running, any noises should be investigated and the cause remedied. A stethoscope is a great help in locating the source of noise. A stethoscope having a long probe will permit listening to the center bearing while the machine is in operation and is most useful.

Generally a loose bearing will produce a dull thud or knock (a loose anchor bolt can produce a similar sound), while looseness in other parts of the conveyor will produce a sharper more metallic sound. Rubbing seals will generally produce a grinding sound. With a little experience in the use of the stethoscope the exact source of the noise can be quickly located.

A knock caused by looseness in a bearing can be corrected by driving the bearing farther onto the adaptor sleeve, it is necessary to remove the drive from the conveyor to do this. Do not allow the conveyor to operate with loose, knocking bearings as serious damage to the eccentric shaft, the adaptor sleeves, or to the bearings themselves can be caused by only a few hours of operation, loose bearings can also cause breakage of the bolts in the clamp blocks which attach the drive to the pan.

The temperature at which the bearings operate is influenced by the temperature of the surrounding air and by the type and quantity of lubricant in the bearing housings. Under normal conditions the temperature of the outside surface of the bearing housings should not exceed 160 degrees Fahrenheit. The cause of excessively high temperatures should be determined and corrected. High temperatures may be caused by an improper grade of lubricant, rubbing seals, or insufficient clearance in the bearings.

The rubber bushing in the upper end of the connecting rod should be inspected periodically. Small rubber particles around the ends of the bushing indicate normal wear. If large pieces of rubber have broken out or the rubber appears badly deteriorated, the bushing should be replaced.

DRIVE ASSEMBLY INSTRUCTIONS

(See illustration on page 12. See page 13 for part number identification)

1. Press the rubber bushing into small end of the connecting rod until it is centered in the rod. Apply force to the outer sleeve of the bushing.

2. Clean all grease out of the center bearing. Coat the bore of the connecting rod and the bore of the bearing with anti-seize compound. Press the bearing into the large end of the connecting rod until it is centered in the rod. Apply force to the outer race of the bearing to prevent damage to it.

3. Install a Rollpin in the 1/8" hole in the eccentric portion of the shaft. Coat the bore of the adaptor sleeve with anti-seize compound and assemble the adaptor sleeve on the shaft with the large end against the Rollpin. Assemble the connecting rod and bearing on the adaptor sleeve. Coat the threads and face of the bearing locknut with anti-seize compound and assemble the lock washer and locknut on the sleeve. The slot in the sleeve should be revolved 90 degrees from the keyway in the shaft.

4. Tighten the connecting rod bearing by exerting a tightening torque on the locknut while striking the face of the nut with a soft hammer. This tightening forces the bearing onto the tapered adaptor sleeve and expands the inner race resulting in a reduction of internal clearance in the bearing. The bearing should be tightened to a final internal clearance of from .0005" - .0015". This clearance is measured between an unloaded roller and the outer race by means of a feeler gauge. After the correct internal clearance has been obtained, bend one tang of the lock washer into a notch in the locknut and pack the bearing half full of grease.

5. Press the seals for the connecting rod bearing into the seal carriers so the lip of the seal is toward the bottom of the recess in the carrier – use care to prevent damage to the seals. Assemble the seal carriers on the connecting rod so the drain plugs are in the proper location.

6. Assemble one pillow block seal ring onto the eccentric shaft and slide it beyond the Rollpin hole. Install the Rollpin in the hole. Coat the bores of the pillow block adaptor sleeve on the shaft and with the large end against the Rollpin and install the bearing on the sleeve. Coat the thread and face of the bearing locknut with anti-seize compound

and assemble the lock washer and locknut on the sleeve. The slot in the sleeve should be revolved 90 degrees from the keyway in the shaft.

7. Tighten the pillow block following the same procedure as was used for the connecting rod bearing to obtain a final internal clearance of from .0005" to .0015". Bend one tang of the lock washer into a notch in the locknut and pack the bearing half full of grease.

8. Assemble the other pillow block seal ring onto the eccentric shaft. Thoroughly clean both halves of the pillow block housing and coat the bearing seats with anti-seize compound. Place the shaft and bearing into the lower half of the housing, move the seal rings so they go into the grooves in the housing. Install the stabilizing ring between the bearing and the housing shoulder on the locknut side of the bearing. Place the top half of the housing on the lower half and install and tighten the bolts which clamp it in place. Note: The upper half of each pillow block must be assembled with its mating lower half as these parts are not interchangeable.

9. Assemble the second pillow block on the other end of the eccentric shaft following the same procedure as was used for the first pillow block except that a stabilizing ring is not used.

NOTE:

In order to prevent noisy bearings and premature bearing failure, the connecting rod and pillow block bearings must have the correct internal clearance and the pillow blocks must have the correct clearance between the housing and the bearing. If replacement bearings are purchased from a source other than Webster, be certain that they have the correct internal clearance. If pillow blocks are either rebuilt or purchased from a source other than Webster, the clearance between the bearing outer race and the housing must be checked and, if excessive, a shim must be added. To check this clearance, clean the housing bore and the bearing O.D., place the bearing in the lower half of the housing, place a short piece of Plastigage on top of the bearing, install the cap on the housing and tighten, remove the cap and determine the clearance by measuring the width of the Plastigage using the scale printed on the paper sleeve in which the Plastigage came. If the clearance exceeds .002", add a shim between the bearing and the housing to reduce clearance. Shim thickness should be somewhat less than one half

of indicated clearance to reduce clearance to .0005" to .0020".

lube fitting when the pillow block is assembled.

The shim size should be as follows:

P3000 Drive 13/16" wide x 10" long.

P5000 Drive 1 - 1/16" wide x 13 - 1/2" long

The gap between the ends of the shim should be under the

- Plastigage is made by Perfect Circle and can be purchased from automobile supply stores.

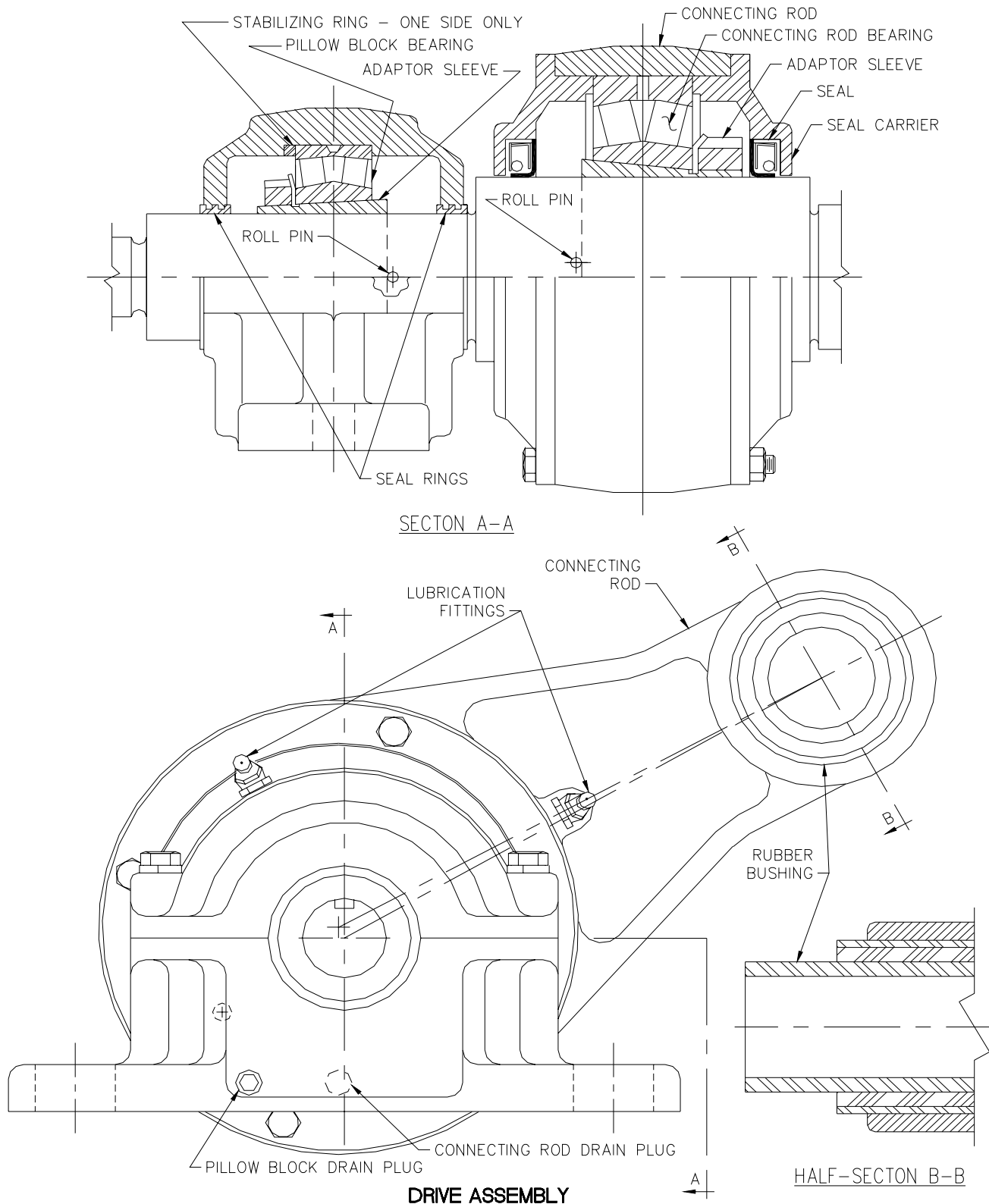

PILLOW BLOCK ASSEMBLY
SEE REBUILD & ASSEMBLY INSTRUCTIONS
IN THE OPERATIONS MANUAL

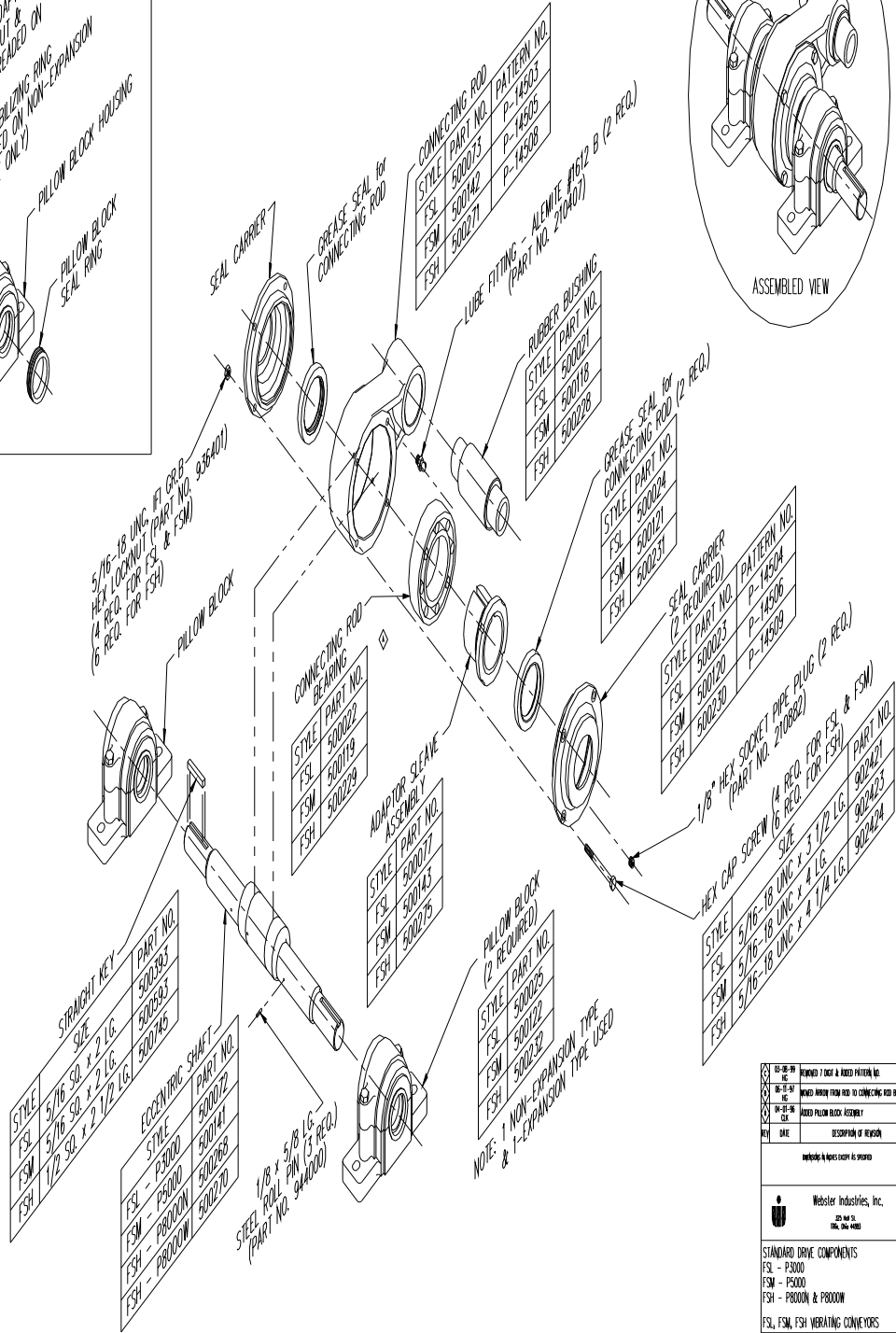
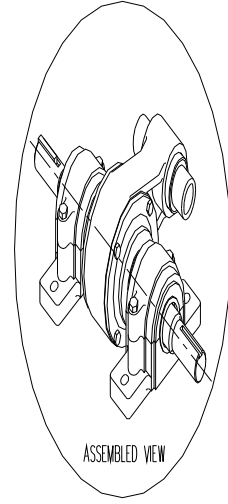
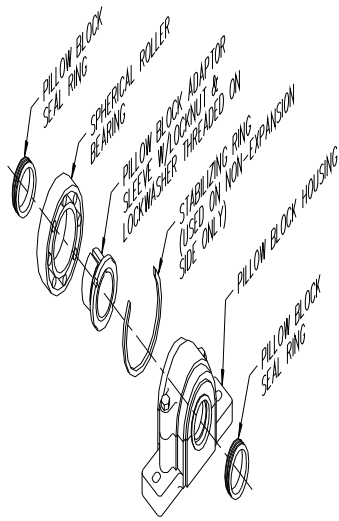

03-28-99 REVISED 7 FOOT & 8 FOOT PATTERNS
05-28-97 REV. ADDED AMOUNT FROM NEED TO CONNECTING ROD BEARING
04-28-96 REV. ADDED PILLOW BLOCK ASSEMBLY
DATE DESCRIPTION OF REVISION

Webster Industries, Inc.
P.O. Box 55
P.O. Box 1000

STANDARD DRIVE COMPONENTS
FSL - P3000
FSM - P5000
FSH - P8000 & P8000

FSL, FSM, FSH VIBRATING CONVEYORS

Customer

Dr.	Dr.	Dr.	AS
-----	-----	-----	----

Date: 03-28-99 Size: 3-1/4" Dia.

Weight: 10

D-33753

TROUBLE SHOOTING

I. Conveyor won't start

- A. Timing pin not removed
- B. Drive out of time (see instruction manual)
- C. Motor is not properly wired
 - i. Motor is for wrong voltage
 - ii. One lead open or poorly connected
 - iii. Low voltage – 10% drop in voltage will result in 20% drop in starting torque – check at motor while motor is energized
- D. Too much and/or wrong kind of grease in bearings – particularly in cold weather
- E. Drive out of line so seals rub badly
- F. Pan is immobile
 - i. Shipping blocks not removed
 - ii. Pan jammed against hopper, etc.
 - iii. Ground welded to pan
- G. Excessive bin or hopper load on pan

II. Conveyor is noisy

- A. Loose bearings
- B. Loose or broken anchor bolts or welds
- C. Loose or broken bolts or welds anywhere on conveyor
- D. Rubber bushing loose or has failed

III. Drive bearings are hot

- A. It's normal to run as hot as 160 F, more when new and full of grease
- B. Too much grease or wrong kind of grease
- C. Seals rubbing
- D. Bearing too tight

IV. Drive seems to slip out of time

- A. build up of material under pan or between pan and stationary equipment or structures

V. Spring bolts are breaking

- A. Wrong bolts or bolts are not properly tightened
- B. Shims missing between spring layers
- C. Surface under bolt head and/or nut chewed up so bolt is bent on fastening
- D. Conveyor out of alignment
- E. Base flexing or moving relative to the foundation
- F. Excessive load on the conveyor (see Section VI)

VI. Clamp block bolts breaking

- A. Wrong bolts or bolts not properly tightened
- B. Surface under bolt head and/or nut chewed up so bolt is bent on fastening
- C. Surface of drive bracket and/or clamp blocks chewed up due to clamp blocks slipping
- D. Hole in clamp block and/or pin in bushing chewed up so pin is not clamped when bolts are tightened
- E. Loose bearings (loud knocking)
- F. Excessive loads on drive – rubber bushings runs hot and fails rapidly

- i. Weight added to pan or build-up on pan
- ii. Operating frequency has been increased
- iii. Broken springs

VII. Pan flange bolts breaking

- A. Wrong bolts or bolts not properly tightened
- B. Flange bars not square on pan – remove and relocate or weld joint
- C. Sections not properly aligned
 - i. Initial misalignment
 - ii. Foundation settling unevenly
 - iii. Foundation in two or more sections which are moving with respect to each other
- D. Support structure warped due to settling of foundation under support posts or columns
- E. Excessive flexing of support structure
- F. Loose or missing springs
- G. Base moving relative to the foundation

VIII. Breakage of infeed spouts on chipper or hog infeed conveyors

- A. Spout is too close to rotor considering length of material – the longer the slabs, etc. the greater the distance from the end of the spout to the rotor
- B. Material build-up under infeed spout. It may be necessary to seal between pan and infeed spout
- C. Slabs jam in infeed spout
- D. Too much clearance between long side of pan and side of chipper infeed spout

Webster Chain, Sprockets and Associated Products People, Products, and Service



At Webster, we have been making engineering class chain for over a century and a quarter.

Webster gives more attention to service than most chain producers. Because we are “Made in USA” chain specialists, we can handle small and special orders, deliver sooner and furnish more technical assistance. We also stock many of the more popular chains. Together with the Webster distributor in your area, we can be a helpful partner with you when you require chain products.



WEBSTER

SINCE 1876

Manufacturing Facility in Tiffin, OH



HISTORY

Since 1876 Webster Industries, Inc has provided conveying solutions of all types to a broad range of markets with a variety of products and expertise. Towner K. Webster founded Webster Industries with his "Common Sense" elevator bucket in Chicago, Illinois. In 1907 Webster relocated to Tiffin, Ohio where our corporate headquarters reside today. Over the past century Webster has evolved from producing elevator buckets to being the world's leading manufacturer of engineered class chains, commercial castings and vibrating conveyors

LOCATIONS

Our Tiffin headquarters has over 300,000 square feet of manufacturing space and includes a malleable iron foundry, punch press operations, heat treat facility, machine shop, sheet metal fabrication department, chain assembly area, in-plant laboratory and testing facilities. Our two warehousing and assembly locations located in Meridian, Mississippi and Tualatin, Oregon allow for quick access to over \$7 million dollars of inventory throughout North America. Our three manufacturing facilities stock over 250,000 feet of chain to serve our customer requirements.

VERTICAL INTEGRATION

Vertical Integration Manufacturing system-While most other companies rely increasingly on outsourcing to produce its products, Webster Industries continues to invest heavily in our vertical integration. To Webster, vertical integration guarantees superior product design, consistent product quality, and the best deliveries in the industry. All aspects of your chain are made under one roof in Tiffin, Ohio. Webster's reputation for high quality products comes from the same principles it was founded on American materials, American labor and American pride. American Materials, Labor, and Pride.

Chain Assembly



Sheet Metal



Heat Treat



Foundry



Machine Shop



Punch Press

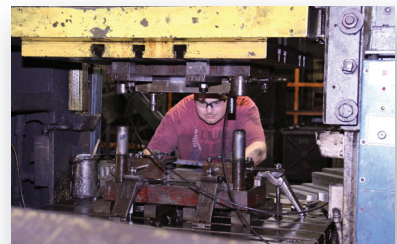

WARNING

**Never operate Machine with Guards Removed
Disconnect and Lockout Power Before Removing Guards to Service Equipment**



WEBSTER

SINCE 1876

websterchain.com • 800.243.9327

ISO9001 Registered