



ASPHALT INDUSTRY

CHAINS · SPROCKETS

ENGINEERED TO EXCEL

MANUFACTURED TO EXCEED



ABOUT US

Webster Industries, Inc., headquartered in Tiffin, Ohio, is an innovative leader in the engineered class chain, sprocket and vibratory equipment markets. Since its start in 1876, Webster has evolved into a vertically integrated chain manufacturer that serves a variety of industries. The company now employs around 300 people nationwide and has facilities in Ohio, Mississippi and Oregon. Throughout its 140 years in business, Webster's focus has consistently been on American materials, American labor and American pride. A strong concentration on customer service, based on seamless vertical integration ensures that Webster's clients receive the highest quality products and service in the industry.



VERTICAL INTEGRATION

While many companies rely increasingly on outsourcing for production needs, Webster Industries has invested in building, maintaining and growing a vertically integrated manufacturing system. With full services under one roof at our Tiffin, Ohio, headquarters, Webster offers superior product design, consistent product quality and the best delivery time in the industry. Our 350,000 square foot manufacturing facility includes the following departments:

- Punching & Stamping
- Heat Treat
- Machining & Sprocket Fabrication
- Metal Fabrication
- Chain Assembly & Welding

OUR PRODUCTS



ENGINEERED CLASS CHAINS



SPROCKETS

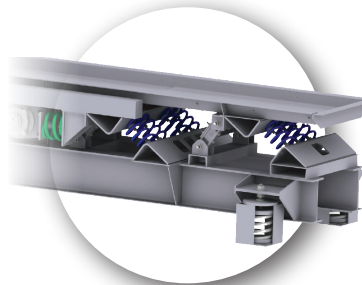

VIBRATING CONVEYORS

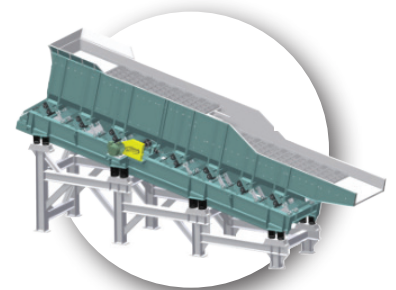

ACTION PROCESS EQUIPMENT



Webster Industries utilizes a variety of manufacturing processes to ensure the highest quality solution is delivered to our customers. Webster's burnished holes and induction hardening are two of those value-added processes.

THE BEST HOLE IN THE INDUSTRY

Burnishing is a unique cold-forming process where a graduated mandrel (punch) is used to punch the sidebar pitch holes. First, the punch pierces the sidebar material, producing a heavy tapered slug. The punch rubs the metal surface of the pitch hole with sufficient force to cause plastic flowing of the metal. This rubbing or smearing (burnishing) action of the metal fills the breakout or tapered portion of the hole that was produced during the initial piercing operation. Single punched holes, as shown in Figure 1.1 below, only allow for 15-20% bearing surface. Punch & shaved holes, as shown in Figure 1.2 below, allow for 60-75% bearing surface. Webster's burnished holes achieve 85-90% bearing surface, as shown in Figure 1.3. Compared to single punched holes, burnished holes allow at least five times more surface against which the pin can rest, resulting in minimized material deformation of the hole under heavy loads.

The burnishing process results in a high quality, tighter tolerance, fatigue resistant, work hardened side bar holes, which are all primary keys to extend chain life. The major advantages of burnished pitch holes are the amount of bearing surface, accuracy of hole size and consistency of press fit.

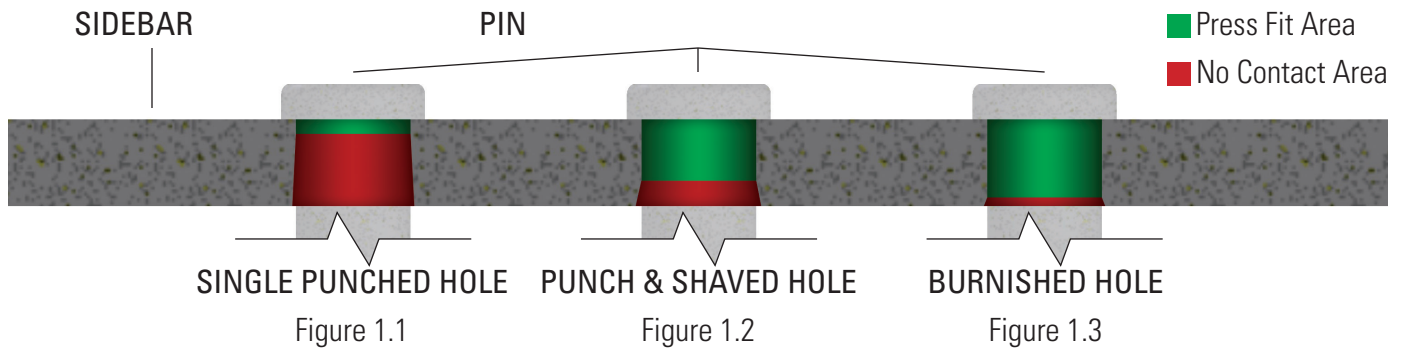

THE BEST PIN IN THE INDUSTRY

Induction hardening is a non-contact heating process that utilizes the principle of electromagnetic induction to produce heat inside the surface layer of a workpiece. By placing a conductive material (pin) into a strong alternating magnetic field (coil), electrical current can be made to flow in the material, creating heat. The current generated flows predominantly in the surface layer of the part; the depth of the hardened layer is determined by the frequency of the alternating field, the surface density and permeability of the material, the heat time, and the pin diameter or material thickness. Then, by immersing the part in a water, oil or polymer-based quench, the surface layer is altered to form a martensitic structure which is harder than the base metal. The core of the material remains the same, and its original properties are unaffected by the induction hardening process.

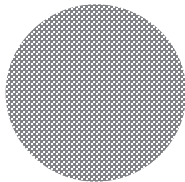

WEBSTER THRU-HARDENED PINS

Webster's pins are made of Duralloy®, thru-hardened to 35/40 Rc where the diameter is less than 3/4".

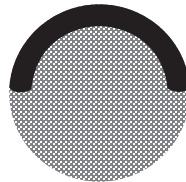

WEBSTER COMPETITORS SELECTIVE INDUCTION HARDENING

Typically, other companies harden only the area that will experience wear. The pin must be oriented properly during assembly to receive the benefit of the induction-hardened surface, and the stop and start area of this induction-hardened zone can promote cracking, ultimately leading to chain failure.

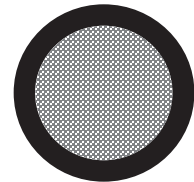

CIRCUMFERENTIAL INDUCTION HARDENING

The load-bearing surface of the thru-hardened pin is induction hardened to 55/60 Rc to the appropriate depth typically 10% of the body diameter is 360°. The IH areas extend into the press fit areas of the pin to maintain the integrity of the pin and guard against failure due to pin shear. This also puts the IH stop and start areas under compression, eliminating potential cracking.

STEEL BUSHED ROLLER CHAINS



Steel bushed roller (SBR) chains are used for a broad range of conveyor and elevator applications. Asphalt SBR chains are designed to replace original equipment chains used in hot asphalt elevating scraper conveyors. They are the appropriate selection for long life and heavy-duty service where difficult operating conditions prevail.

MATERIAL

Sidebars are heat-treated, medium carbon steel. Pins are alloy steel, through hardened and induction hardened to provide maximum toughness, excellent wear resistance and a flexible inner core to deliver the ultimate chain life. Bushings are case hardened steel to provide maximum wear resistance and chain life. Rollers normally provided as plain tread and plain faced.

ASSEMBLY

SBR chains for elevators are typically furnished in cottered construction.

INTERCHANGEABILITY

SBR chains are interchangeable with other standard makes of corresponding sizes and numbers.

APPLICATION

SBR chains are used in bucket elevators, flight conveyors, scraper conveyors and other conveying applications where difficult operating conditions prevail. The roller provides a lower operating friction to help increase chain life, decrease Rated Working Load requirements and reduce conveyor design requirements.



OPERATION

SBR chains are designed for slow or moderate-speed applications. Maximum chain speed depends upon size of sprockets. For Maximum Recommended Conveyor Speed see Table 2, Section A, in the Webster #400 Master Catalog.

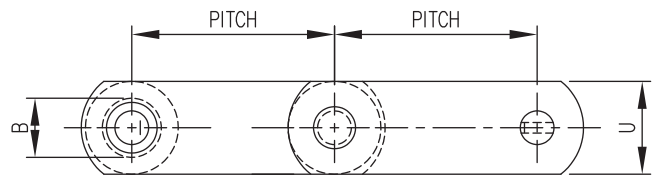
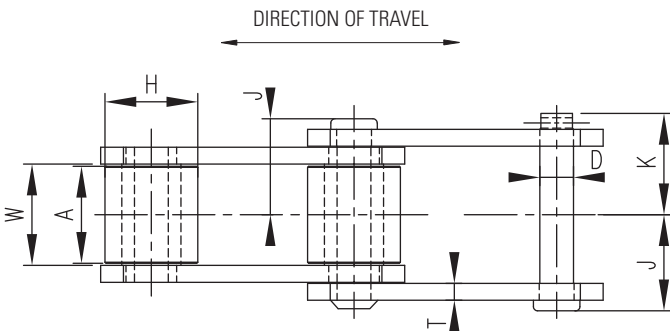

STYLE 1

CHAIN NO.	CHAIN STYLE	AVERAGE PITCH INCHES	APPROX. LINKS IN 10 FEET	AVERAGE WEIGHT PER FT. LBS.	AVERAGE ULTIMATE STRENGTH IN LBS.	RATED WORKING LOAD IN LBS. ☆	GENERAL DIMENSIONS				PINS	
							INSIDE SIDE-BARS	CL TO COTTER END	CL TO HEAD OR RIVET END	DIA.	STYLE	MATERIAL
							W	K	J	D		
S3945	1	4.000	30	6.6	40,000	5,740	2	2 ³ / ₃₂	1 ¹ / ₈	5 ¹ / ₈	B	ALY.I.H.
S3433	1	4.000	30	8.7	40,000	6,290	2 ¹ / ₈	2 ¹ / ₁₆	2 ¹ / ₁₆	5 ¹ / ₈	A	ALY.I.H.
S3433SPC	3	4.000	30	9.2	40,000	6,290	2 ¹ / ₈	2 ¹ / ₁₆	2 ¹ / ₁₆	5 ¹ / ₈	A	ALY.I.H.
S3952	1	4.000	30	8.2	40,000	7,220	2	2 ³ / ₃₂	2 ¹ / ₃₂	3 ¹ / ₄	A	ALY.I.H.
S2268	1	4.083	29	11.9	62,600	7,220	2	2 ³ / ₃₂	2 ¹ / ₃₂	3 ¹ / ₄	A	ALY.I.H.
S3945SPC	1	4.090	30	7.0	40,000	5,740	2	2 ³ / ₃₂	1 ¹ / ₈	5 ¹ / ₈	B	ALY.I.H.
S3945HD	1	4.600	26	13.3	62,600	7,220	2	2 ³ / ₃₂	2 ¹ / ₃₂	3 ¹ / ₄	A	ALY.I.H.
S2035	1	5.188	23	14.4	124,000	9,350	2 ⁵ / ₁₆	2 ³ / ₈	2 ¹ / ₃₂	7 ¹ / ₈	B	ALY.I.H.
S2035HD	1	6.000	20	19.2	100,000	9,375	2 ⁵ / ₁₆	2 ³ / ₈	2 ¹ / ₃₂	7 ¹ / ₈	B	ALY.I.H.
S3940	1	6.000	20	9.7	62,600	7,220	2	2 ³ / ₃₂	2 ¹ / ₃₂	3 ¹ / ₄	A	ALY.I.H.
S9856B	3	6.000	20	22.2	100,000	14,000	3	3	2 ⁷ / ₃₂	1	F	ALY.I.H.

NOTE: ☆ Subject to Service Factor see Table 9 and Speed Factor Table 11, Section A, in Webster #400 Master Catalog.



STEEL BUSHED ROLLER CHAINS

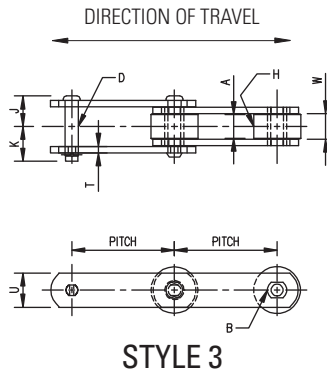
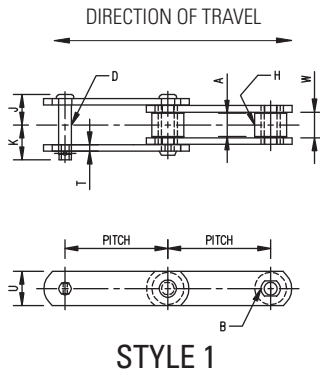

Chain Style Descriptions
 Style 1 Straight Sidebar, Small Roller
 Style 3 Straight Sidebar, Large Roller

BUSHINGS

PINS

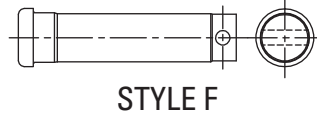
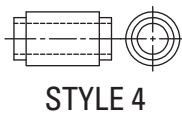
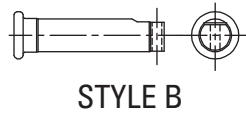
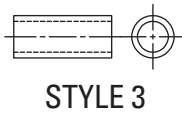
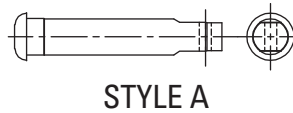
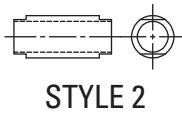

Abbreviations of Material and Treatment
 M.C.H.T. Medium Carbon, Heat Treated
 ALY.I.H. Alloy Steel, Induction Hardened
 L.C.C.H. Low Carbon, Case Hardened
 ALY.C.H. Alloy Steel, Case Hardened

CHAIN NO.	SIDEBARS			BUSHINGS			ROLLERS			COMMON ATTACHMENT NUMBERS
	THK.	HEIGHT	MATERIAL	OUTSIDE DIA.	STYLE	MATERIAL	TREAD DIA.	TREAD WIDTH	MATERIAL	
	T	U		B			H	A		
S3945	5/16	1 1/2	M.C.H.T.	7/8	3	ALY.C.H.	1 1/4	1 1/8	L.C.C.H.	K23, M2
S3433	3/8	1 1/2	M.C.H.T.	1	2	ALY.C.H.	1 1/2	2	L.C.C.H.	K25, M2
S3433SPC	3/8	1 1/2	M.C.H.T.	1	2	ALY.C.H.	1 5/8	2	L.C.C.H.	K25
S3952	3/8	1 1/4	M.C.H.T.	1 1/8	3	ALY.C.H.	1 7/16	1 1/8	L.C.C.H.	K22
S2268	3/8	2 1/2	M.C.H.T.	1 1/8	3	ALY.C.H.	1 5/8	1 1/8	M.C.H.T.	K22, M2
S3945SPC	5/16	1 1/2	M.C.H.T.	7/8	3	ALY.C.H.	1 3/8	1 1/8	M.C.H.T.	K23, M2
S3945HD	3/8	2 1/4	M.C.H.T.	1 1/8	3	ALY.C.H.	1 5/8	1 5/16	M.C.H.T.	K23, M2
S2035	3/8	2 1/2	M.C.H.T.	1 1/4	3	ALY.C.H.	2	2 3/16	M.C.H.T.	K22
S2035HD	3/8	2 1/2	M.C.H.T.	1 3/8	3	ALY.C.H.	2 3/8	2 1/4	M.C.H.T.	K22
S3940	3/8	2 1/4	M.C.H.T.	1 1/8	3	ALY.C.H.	1 5/8	1 1/8	M.C.H.T.	K25
S9856B	1/2	2 1/2	M.C.H.T.	1 3/4	4	ALY.C.H.	2 3/4	2 13/16	L.C.C.H.	K25, M2, M2-9

COMMON SBR CHAIN ATTACHMENTS



K22 +

CHAIN NO.	A	B	C	D	E	F	T	WEIGHT PER FOOT-LBS.	BOLT SIZE
								ΔΔ	
S3952	2 ²¹ / ₃₂	1 ¹ / ₈	1 ¹ / ₈	1 ³ / ₄	6 ¹ / ₄	3 ⁵ / ₈	3 ⁵ / ₈	14.7	3 ⁸ / ₁₆
S2268	2 ²¹ / ₃₂	1 ⁷ / ₃₂	2	1 ³ / ₄	6 ³ / ₈	3 ¹⁵ / ₃₂	3 ⁵ / ₈	20.3	1/2
S2035	3 ¹ / ₈	1 ⁷ / ₁₆	2	2 ⁵ / ₁₆	7 ¹ / ₈	4	3 ⁵ / ₈	19.3	1/2
S2035HD	3 ¹ / ₈	1 ²⁷ / ₃₂	2	2 ⁵ / ₁₆	7 ¹ / ₁₆	4	3 ⁵ / ₈	20.1	1/2

NOTE: S3952 also available with square holes.

NOTE: S3952 can have attachment furnished on inner or outer sidebar.

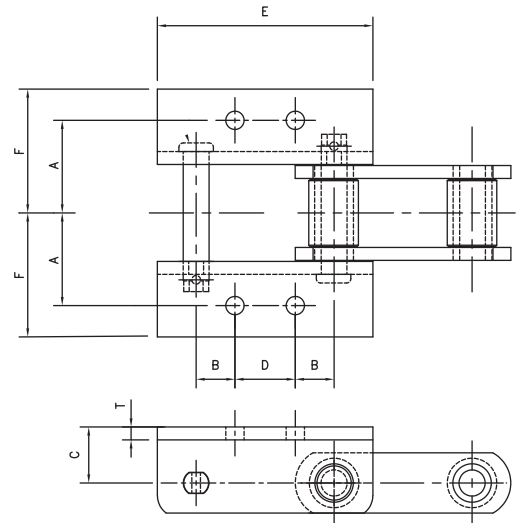

K22

K23 +

CHAIN NO.	A	B	C	D	E	F	T	WEIGHT PER FOOT-LBS.	BOLT SIZE
								ΔΔ	
S3945HD	2 ²¹ / ₃₂	1 ¹³ / ₃₂	1 ¹ / ₂	1 ³ / ₄	6	3 ¹⁵ / ₃₂	3 ⁵ / ₈	13.3	3 ⁸ / ₁₆
S3945SPC	2 ²¹ / ₃₂	1 ⁷ / ₃₂	1 ³ / ₈	1 ³ / ₄	4 ³ / ₄	3 ⁷ / ₃₂	5 ¹ / ₁₆	9.6	3 ⁸ / ₁₆
S3945	2 ²¹ / ₃₂	1 ¹ / ₈	1 ³ / ₈	1 ³ / ₄	6	3 ³ / ₈	5 ¹ / ₁₆	9.6	3 ⁸ / ₁₆

NOTE: S3945 can have attachment furnished on inner or outer sidebar.

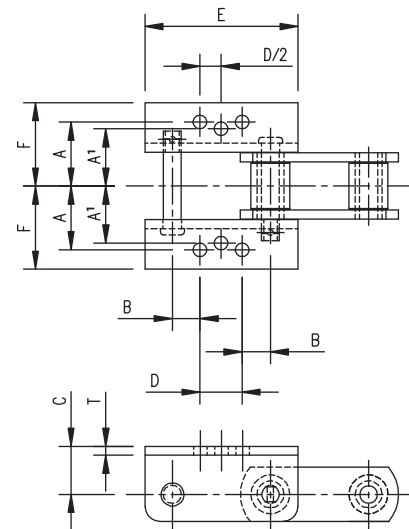

K23

K25 +

CHAIN NO.	A	B	C	D	E	F	T	WEIGHT PER FOOT-LBS.	BOLT SIZE
								ΔΔ	
S3433	2 ²¹ / ₃₂	1 ¹ / ₈	1 ¹ / ₈	1 ³ / ₄	4 ³ / ₄	3 ¹³ / ₃₂	3 ⁵ / ₈	11.5	1/2
S3433SPC	2 ²¹ / ₃₂	1 ¹ / ₈	1 ³ / ₈	1 ³ / ₄	4 ⁵ / ₁₆	3 ¹⁵ / ₃₂	3 ⁵ / ₈	12.0	3 ⁸ / ₁₆
S3940	3 ¹ / ₈	1 ²⁷ / ₃₂	2	2 ⁵ / ₁₆	7 ¹ / ₄	3 ³¹ / ₃₂	3 ⁵ / ₈	14.5	1/2
S9856B	3 ⁵ / ₈	1 ³ / ₄	1 ¹ / ₈	2 ¹ / ₂	7 ¹ / ₂	4 ²³ / ₃₂	1 ¹ / ₂	28.0	3/4

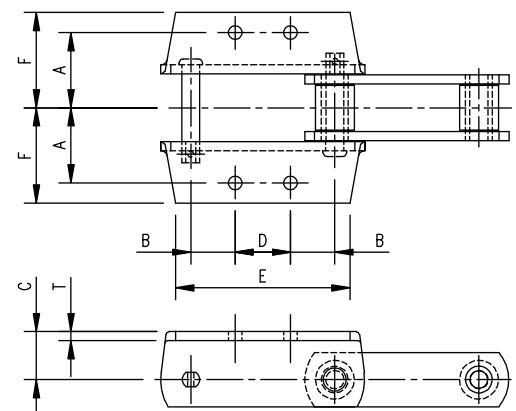

K25



COMMON SBR CHAIN ATTACHMENTS

M2 +

CHAIN NO.	E	F	G	J	L	M	N	WEIGHT PER FOOT-LBS.	
								$\Delta\Delta$	
S3945	3 ³ / ₃₂	4 ¹ / ₂	3/4	1 ¹ / ₁₆	1 ¹ / ₄	2 ¹ / ₂	1 ¹⁹ / ₆₄		9.6
S2268	4 ¹⁵ / ₁₆	6	1 ¹ / ₈	1 ¹ / ₁₆	2	2 ⁷ / ₈	2 ¹ / ₈		17.0
S3945SPC	3 ³ / ₈	4 ¹ / ₂	3/4	1 ¹ / ₁₆	1 ¹ / ₄	2 ¹ / ₂	1 ¹¹ / ₃₂		12.8
S9856B	7 ¹ / ₄	6	1 ¹ / ₂	1 ³ / ₁₆	1 ⁷ / ₈	2 ⁵ / ₈	3 ⁷ / ₃₂		31.4
S3433	3 ²⁵ / ₃₂	6	3/4	1 ¹ / ₁₆	2 ³ / ₄	2 ¹ / ₂	1 ¹⁷ / ₃₂		12.0
S3945HD	4 ²⁵ / ₃₂	4 ⁷ / ₈	1 ¹ / ₈	1 ¹ / ₁₆	1 ¹ / ₄	2 ¹ / ₂	2 ¹ / ₁₆		13.9

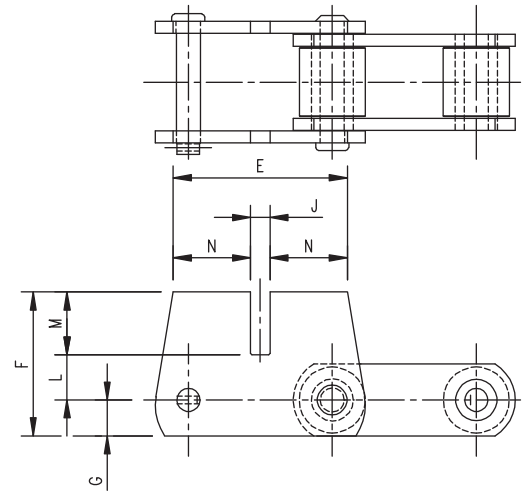

M2

M2-9 +

CHAIN NO.	E	F	G	J	L	M	N ¹	N ²	WEIGHT PER FOOT-LBS.	
									$\Delta\Delta$	
S9856B	7 ¹ / ₄	6	1 ¹ / ₂	1 ³ / ₁₆	1 ¹ / ₄	3 ¹ / ₄	2 ²³ / ₃₂	3 ²³ / ₃₂		31.4

NOTE: Slot is sloped at 9°.

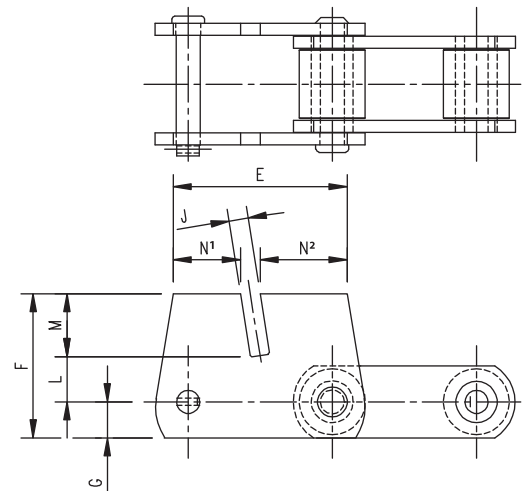

M2-9

- + Attachments on outer sidebars only. Offset links must be used if attachment spacing is odd number of pitches.
- $\Delta\Delta$ Weights of attachments coupled every other pitch. Cannot be coupled consecutively.

WEBSTER INDUSTRIES SLAT ASSEMBLY PROGRAM

Webster has the ability to manufacture custom or standard slats, bars and buckets for any application. This value added service includes welded or bolted slats with various options available. Webster's slat assembly program is a benefit for the following reasons:

- Reduces installation time which saves end users money
- Greatly decreases opportunities for incorrect or poor welds
- Reduces additional onsite work and safety concerns

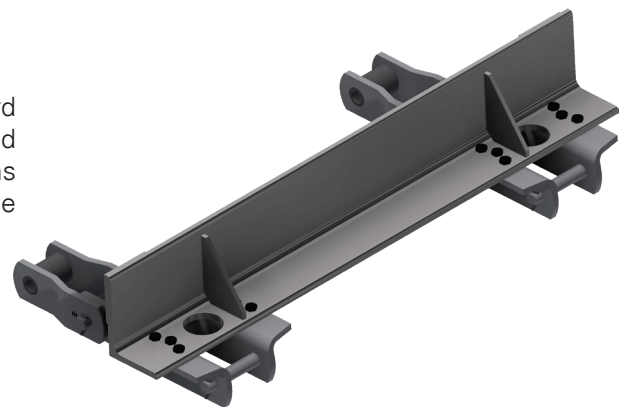



THE WEBSTER VALUE

For over 145 years, Webster has provided conveying solutions to a diverse range of markets with our extensive variety of products and industry expertise. A key to our success is making a difference through industry, work, self, family and community.



AMERICAN MATERIALS, AMERICAN LABOR & AMERICAN PRIDE

Webster's reputation for high-quality products originates from the same principles they were founded on in 1876. Our Made in the USA brand is demonstrated through our domestic supply chain partners and our American workforce.



VERTICALLY INTEGRATED MANUFACTURING FACILITY

While companies are relying increasingly on outsourcing for production needs, Webster has invested in building, maintaining and growing a vertically integrated manufacturing system.

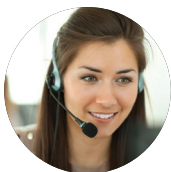

WORLD CLASS CUSTOMER SUPPORT & DELIVERIES

Providing value to customers is Webster's top priority. Our commitment and responsiveness to customers, industry best deliveries and our engineered solutions are what set us apart from the competition.



SUPERIOR QUALITY & INNOVATION

Webster's strict manufacturing, ISO quality standards and continuous innovation ensure that we are providing our customers with the highest quality products in the industry.

ESTABLISHED 1876