

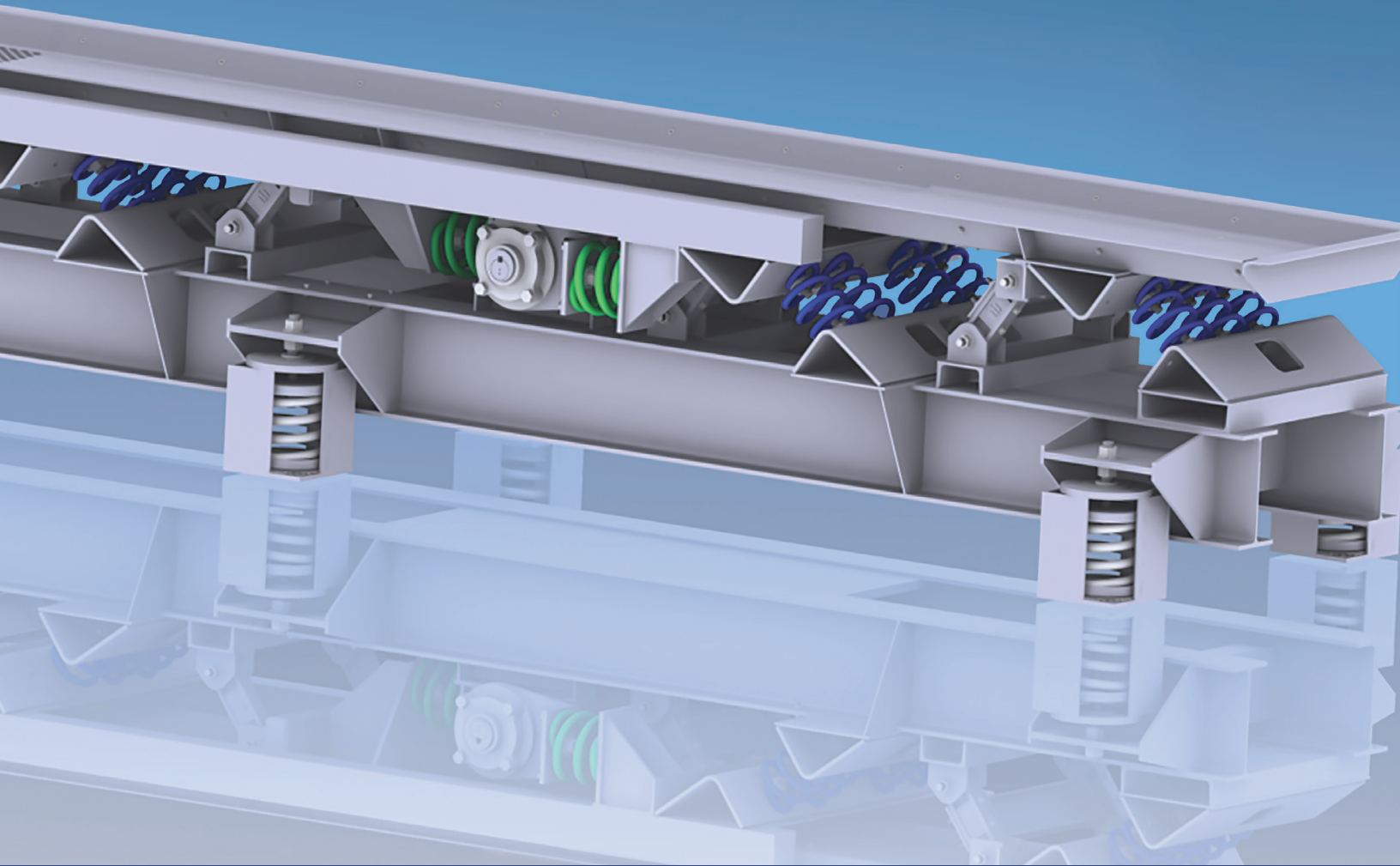

VIBRATING CONVEYORS



ENGINEERED TO EXCEL

MANUFACTURED TO EXCEED

WEBSTER FS SERIES AND COILWEB® VIBRATING CONVEYORS



DESIGN BENEFITS

- Can readily handle hot or abrasive materials.
- Handles fragile materials (potato chips, cereal flakes, etc.) without degradation.
- Smooth continuous trough – no pockets for material to accumulate in or jamming of material.
- Conveyor is normally self-cleaning.
- No return strand to carry over.
- Simple construction with minimum number of moving parts.
- Moving parts are not in contact with material.
- Minimum safety hazard to persons working on or near conveyor.
- Pan is usually widest part of conveyor.
- Pan is easily enclosed, even at transfer points.
- Discharge end may be tapered to spread material.
- Abrupt discharge.
- Little headroom required for change in direction or discharge to other equipment.
- Problems at discharge or transfer points are minimized by lower conveying speed, low headroom and abrupt discharge. If problems do occur, they are easily corrected by modifying end of pan.
- Multiple discharge points are possible.
- Conveyor can perform special operations (scalping, dedusting, magnetic separation, lump breaking, washing, heating, cooling, drying, etc.) while conveying.
- Unit machines have been completely assembled and tested at the factory, allowing for minimum work and time at installation.

DESIGN LIMITATIONS

- Not all materials can be conveyed.
- Not a positive type of conveyor; conveying speed obtained may vary with different materials.
- Degree of slope for conveying is limited.
- Substantial foundation, supporting structure or special construction is required with unbalanced forces.
- Limited length of conveyor per drive.

DESIGN FEATURES

• **Controlled Vibration**

The movement of material on the pan of a vibrating conveyor is dependent on the vibratory motion of the pan. On all Webster vibrating conveyors, amplitude, direction and frequency of the vibratory motion are selected and controlled. This provides a gentle hopping action to the material being conveyed, minimizing material degradation, wear of the conveying surface, noise level and drive forces. Selecting the amplitude and frequency of vibration also ensures oversize motors are not required for starting.

• **Natural Frequency**

When the stiffness of the springs which support and guide the pan is selected so the natural or resonant frequency of the pan-spring system is nearly the same as the operating frequency of the conveyor, most of the power required to vibrate the empty pan is alternately stored and released by the springs. It is necessary only for the drive to furnish the power required to overcome frictional forces and to convey material. This results in minimum power requirements, minimum drive forces and a uniform distribution of inertia forces over the length of the conveyor. All Webster vibrating conveyors employ this operating principle.



WEBSTER FS SERIES AND COILWEB® VIBRATING CONVEYORS

Selecting the proper size and type of vibrating conveyor is based on the following three factors:

1. **Quantity of material to be conveyed.**
2. **Properties of the material to be conveyed.**
3. **Environment in which conveyor will be installed.**

Quantity of material to be conveyed is usually stated in tons per hour. However, since the vibrating conveyor is a volumetric device, it is necessary to select a unit to contain and convey the largest instantaneous volumetric flow rate which may occur. For example, if a conveyor receives material from a batch weighting hopper, it must be sized to convey at the maximum rate at which material is discharged from the hopper rather than at the average hourly rate. If a conveyor is to handle unit loads such as foundry molds, the cross sectional area of the pan must be somewhat larger than the vertical cross sectional area of the load so the load will be contained without spillage.

Material properties include bulk density, particle size, abrasiveness, corrosiveness, stickiness and temperature. Bulk density, together with the capacity in tons per hour, determines the volumetric flow rate. Particle size has two important aspects. First, the conveyor pan must be somewhat wider than the largest piece of material which will be conveyed. Material has less tendency to jam in pans with flared sides than in pans with straight or vertical sides. Second, materials of very small particle size may convey poorly and have severe limitations on the depth of the bed which can be conveyed. Abrasive materials may require pans fabricated of abrasion-resistant steel or liners of abrasion-resistant steel or rubber. Corrosive materials may require pans fabricated of, or lined with,

special materials. Sticky materials may require special liners or coating. The temperature of the material will determine whether standard non-expansion construction will be satisfactory or if high temperature heat-expansion construction is necessary.

Environment includes ambient conditions (hot, humid, corrosive or dusty atmospheres) and the type of support available for the conveyor. High ambient temperatures may require a supply of cooling air for the motor, V-belt drive and conveyor drive and an air-oil mist lubrication system for the drive bearings. A humid, corrosive or dusty atmosphere may require special coatings for the conveyor or an air-oil mist lubrication system for the drive bearings. If the conveyor is to be installed in an elevated structure, adjacent to equipment which would be adversely affected by vibration or in an area with poor soil conditions, a conveyor that counterbalances or isolates the dynamic reactions may be required.

The following table lists the maximum allowable material temperature for Webster vibrating conveyors. It is intended as a guide only and is based on the assumption that the bottom of the pan is completely and continuously covered with a bed of material.

MAXIMUM ALLOWABLE MATERIAL TEMPERATURE

MODEL	STANDARD CONSTRUCTION	HEAT-EXPANSION CONSTRUCTION
FSL	150° F	CoilWeb®
FSM	150° F	CoilWeb®
FSH	150° F	CoilWeb®
COILWEB®	200° F	800° F

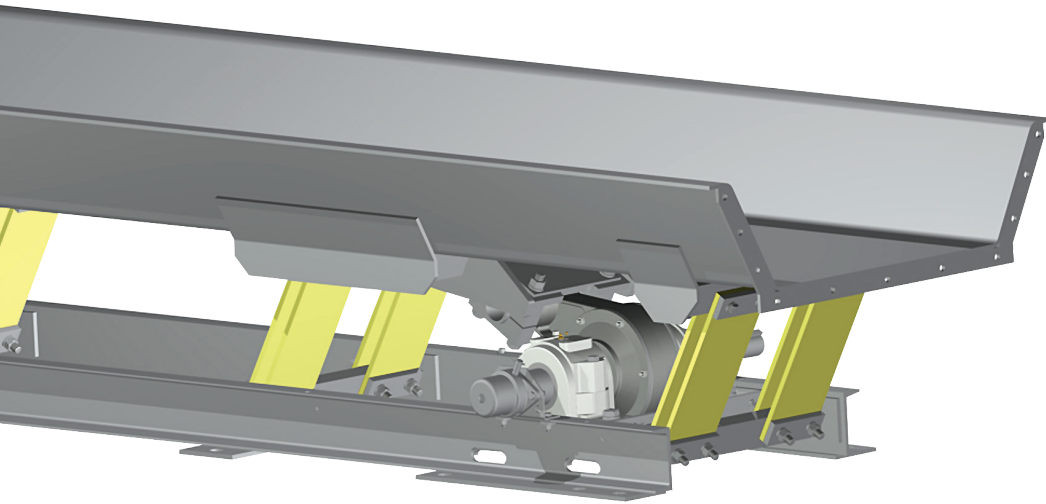

This series includes the FSL, a light-duty, low-headroom conveyor for small-particle, low-capacity applications; the FSM, a medium-duty conveyor for small-particle, high-capacity applications; and the FSH, a medium- to heavy-duty conveyor for a larger particle size and increased capacity applications. All FS conveyors incorporate the natural frequency principle, controlled vibration, positive eccentric drive and standardized sectional construction. They provide a rugged and economical answer to many bulk material conveying and processing jobs.

FS series vibrating conveyors will convey granular or lump material ranging in size from minus 100 mesh to

any lump size which will fit into the pan. They can handle weight from several pounds to several hundred pounds per cubic foot, and are particularly effective for conveying heavy, sharp or abrasive materials that are not readily handled on other types of conveyors. They also may be adapted to processing operations, such as inspecting, sorting, screening, washing, dewatering, heating, cooling and drying.

The following pages detail the dimensions of our standard pan sizes. Other pan sizes and shapes are available. FS series vibrating conveyors can be custom-designed for your application.

MATERIAL

FS series vibrating conveyors incorporate fabricated steel pans, a natural frequency spring system, a positive eccentric drive powered by an electric motor and v-belts on an adjustable base.

ASSEMBLY

Standard drive and extension sections are delivered in preassembled sections. Jig-fixtured, bolted pan flanges make field assembly easy.

APPLICATION

FS series vibrating conveyors are used where horizontal or shallow incline conveying is required. They handle a wide variety of bulk materials, from powders to solids. They are designed to handle fragile, sharp and irregularly shaped materials, and are primarily used in the forest products, stamping, food, grain and chemical industries.



FLAT SPRINGS

The springs used in FS series vibrating conveyors are fabricated of a glass filament reinforced plastic that has extremely high flexural strength and excellent resistance to heat, moisture and chemical exposure. These springs are conservatively stressed and will have an extremely long life if the conveyor is properly installed and maintained.

POSITIVE ECCENTRIC DRIVE

Very little driving force is required when a vibrating conveyor is operating without load and at or close to its natural frequency. The material being conveyed or a buildup of material on the pan will cause connected increases in the driving force required. The positive connected eccentric drives used in FS series vibrating conveyors will maintain constant amplitude under the variations in loading which occur during normal operation.

These drives are equipped with heavy duty spherical roller bearings on the eccentric shaft and a steel-encased rubber bushing at the pan end of the connecting rod. This rubber bushing reduces drive forces when starting and stopping, eliminates the need for lubrication at this point, and reduces the noise level of the machine. The bearing seals are designed so that they cannot be damaged by excessive lubrication.

STANDARDIZED SECTIONAL CONSTRUCTION

FS series vibrating conveyors are standardized sectional conveyors. They are built in 10-foot sections that are bolted together. Odd-length sections are available for use at the ends of the conveyor when the length is not a multiple of 10 feet. The pans are fabricated of mild carbon steel. The thickness and cross-sectional dimensions of the pans for the various standard sections are shown on the following pages. Pans fabricated of other materials or

having different dimensions are available.

UNBALANCED OR ISOLATED CONSTRUCTION

Standard FS series vibrating conveyors are unbalanced machines and must be installed on a substantial foundation or supporting structure which is usually at or below ground level. If the conveyor is to be installed on an elevated structure, it is necessary to reduce the dynamic reaction transmitted to the supports, and it may be equipped with a heavy inertia base and soft isolating springs. This type of construction will reduce the forces transmitted to the support by 85% to 95%.

STANDARD AND HIGH-TEMPERATURE CONSTRUCTION

Webster FS series vibrating conveyors are available in two types, depending on the temperature of the material being conveyed. When material temperature is no higher than 150°F, standard or nonexpansion construction is used. For hotter materials, high temperature or heat expansion construction can be used or a switch to CoilWeb® series may be recommended. The high-temperature type is designed to allow the pan to expand and contract so thermal expansion is controlled.

ACCESSORIES

A wide range of optional features are available for FS series vibrating conveyors, including covers; side or bottom discharges; intermediate discharges with gates; pans with multiple compartments or channels; screen sections; nonmagnetic pan sections for use with magnetic separators; nonmetallic pan sections for use with metal detectors; steel pan liners for impact or abrasion resistance; rubber pan liners for wear resistance or noise reduction; special discharges for feeding process equipment; and steel support structures.



The motor size and capacity charts are based on a conveying speed of 25 FPM at $\frac{1}{2}$ " stroke and 585 RPM operating frequency. The nominal rated capacity of these standard-model Webster FSL vibrating conveyors is shown in the following chart.

CONVEYOR LENGTH AND MOTOR SIZE

Pan Size			Base Size	Stroke	Operating Frequency	Motor Size (1200 RPM)			
Width	Depth	Thk.				1 HP	2 HP	3 HP	5 HP
12/16	4"	10 Ga.	Narrow	$\frac{1}{2}$ "	585 RPM	29'-0"	74'-0"	122'-0"	—
12/18	6"	10 Ga.	Narrow	$\frac{1}{2}$ "	585 RPM	24'-0"	63'-0"	104'-0"	—
18/22	4"	$\frac{3}{16}$ "	Wide	$\frac{1}{2}$ "	585 RPM	15'-0"	40'-0"	66'-0"	101'-0"
18/24	6"	$\frac{3}{16}$ "	Wide	$\frac{1}{2}$ "	585 RPM	13'-0"	35'-0"	59'-0"	90'-0"

CAPACITY CHART

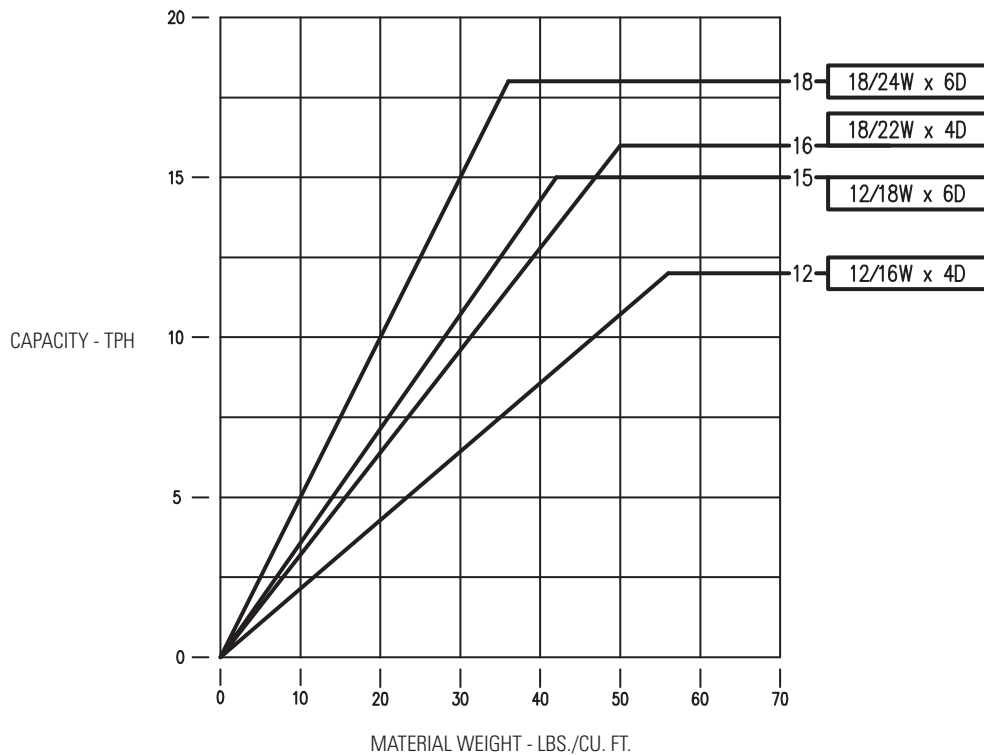



MODEL FSL CONVEYORS

For Light-Duty, Low-Headroom Applications

Webster FSL vibrating conveyors are light-duty, low-headroom models for small particle size and low-capacity applications. They can handle granular or lumpy materials, metal or plastic parts, scrap and food products economically and with minimum power requirements.

In addition to the standard sections shown on the following pages, other pan sizes and shapes, accessories and special features can be supplied.

DRIVE

Webster FSL vibrating conveyors are equipped with the P3000 positive eccentric drive and heavy duty, self-aligning roller bearings.

DETAILS OF CONSTRUCTION

Pans for standard FSL vibrating conveyors are made with

flared sides, so the width is greater at the top than at the bottom. Standard pan bottom widths are 12" and 18". Standard pan thickness is #10 gauge for the 12" and $\frac{3}{16}$ " for the 18" wide.

The base is a heavy, formed-steel channel with the web on top. This style has no pockets on the topside to catch and hold foreign material. The base has anchor bolt pads welded on its underside so it contacts the foundation only where it is attached.

FSL CROSS SECTION DIMENSIONS

Pan Size	A	B	C	D	E	Base
12/16	12"	16"	4"	1 $\frac{7}{8}$ "	1'-1 $\frac{3}{4}$ "	Narrow
12/18	12"	18"	6"	1 $\frac{7}{8}$ "	1'-3 $\frac{3}{4}$ "	Narrow
18/22	18"	22"	4"	3"	1'-2 $\frac{15}{16}$ "	Wide
18/24	18"	24"	6"	3"	1'-4 $\frac{15}{16}$ "	Wide

*10 GA thick for narrow, $\frac{3}{16}$ " thick for wide

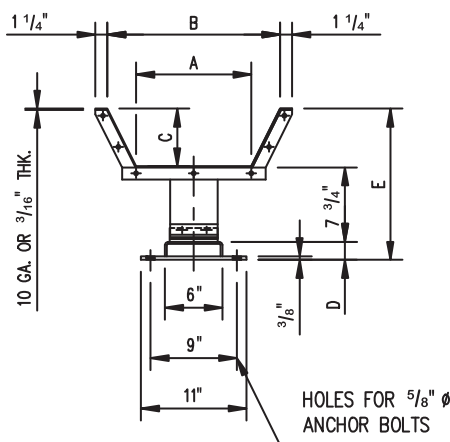

VIEW A-A
NARROW BASE
PAN BOTTOM 8" MIN. TO 15" MAX.

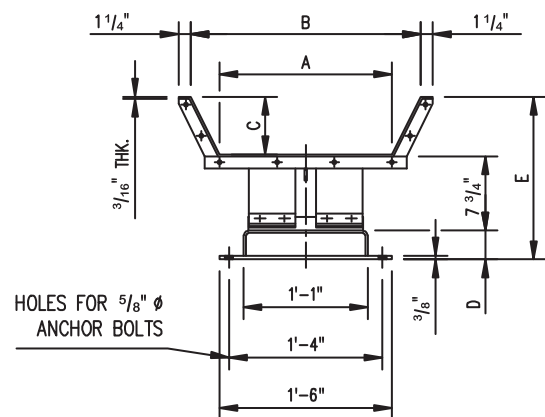

VIEW A-A
WIDE BASE
PAN BOTTOM 15" MIN. TO 18" MAX.

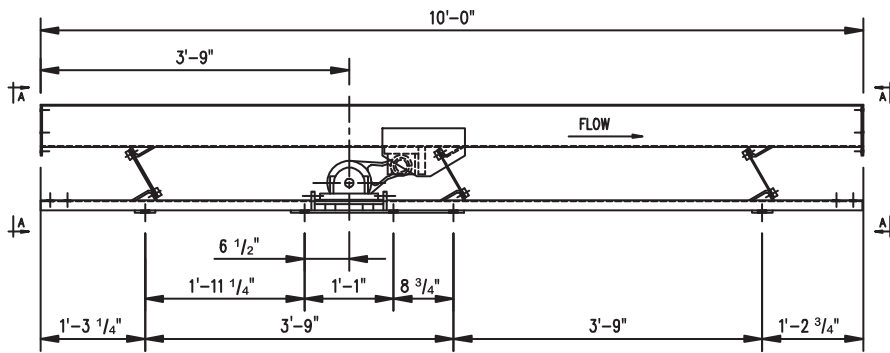

STANDARD DRIVE SECTION

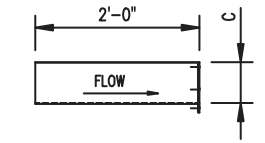

FEED END PAN ADDITION SECTION

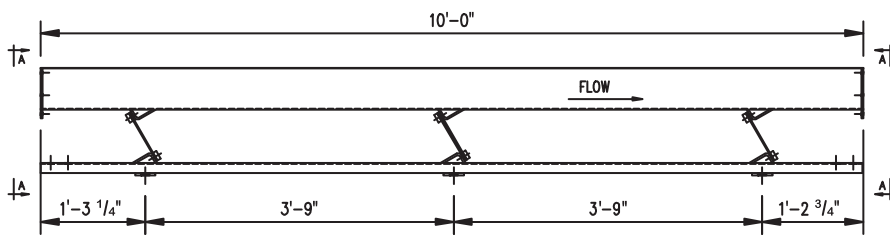

STANDARD EXTENSION SECTION

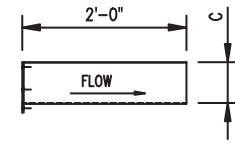

DISCHARGE END PAN ADDITION SECTION

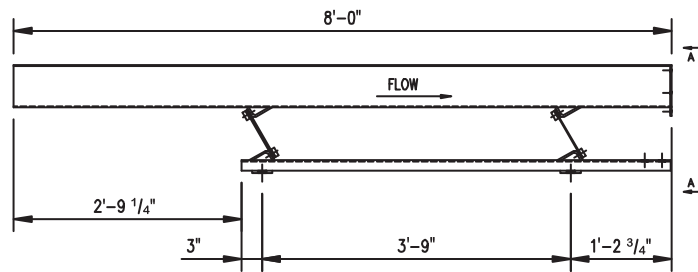
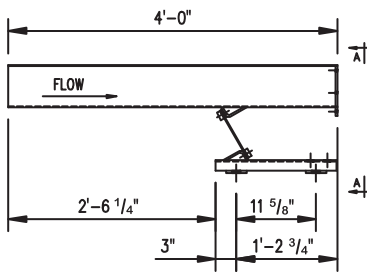

FEED END EXTENSION SECTIONS

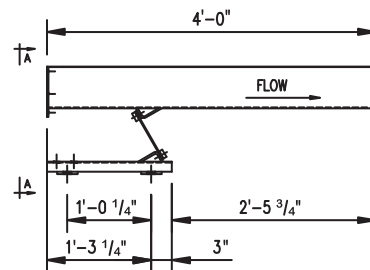
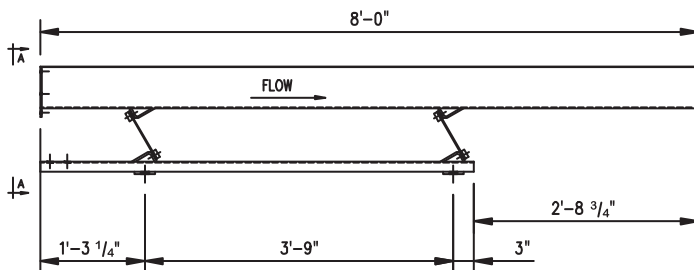

DISCHARGE END EXTENSION SECTIONS



The motor size and capacity charts are based on a conveying speed of 45 FPM at $\frac{9}{16}$ " stroke and 585 RPM operating frequency. The nominal rated capacity of these standard-model Webster FSM vibrating conveyors is shown in the following chart.

CONVEYOR LENGTH AND MOTOR SIZE

Pan Size			Base Size	Stroke	Operating Frequency	Motor Size (1200 RPM)			
Width	Depth	Thk.				2 HP	3 HP	5 HP	7½ HP
18/24	6"	$\frac{3}{16}$ "	Wide	$\frac{9}{16}$ "	585 RPM	25'-0"	43'-0"	67'-0"	99'-0"
18/24	6"	$\frac{1}{4}$ "	Wide	$\frac{9}{16}$ "	585 RPM	19'-0"	32'-0"	51'-0"	75'-0"
18/27	9"	$\frac{3}{16}$ "	Wide	$\frac{9}{16}$ "	585 RPM	21'-0"	37'-0"	57'-0"	85'-0"
18/27	9"	$\frac{1}{4}$ "	Wide	$\frac{9}{16}$ "	585 RPM	16'-0"	27'-0"	43'-0"	64'-0"
24/30	6"	$\frac{3}{16}$ "	Wide	$\frac{9}{16}$ "	585 RPM	20'-0"	35'-0"	56'-0"	83'-0"
24/30	6"	$\frac{1}{4}$ "	Wide	$\frac{9}{16}$ "	585 RPM	15'-0"	27'-0"	42'-0"	63'-0"
24/33	9"	$\frac{3}{16}$ "	Wide	$\frac{9}{16}$ "	585 RPM	17'-0"	31'-0"	49'-0"	73'-0"
24/33	9"	$\frac{1}{4}$ "	Wide	$\frac{9}{16}$ "	585 RPM	13'-0"	23'-0"	37'-0"	55'-0"

CAPACITY CHART

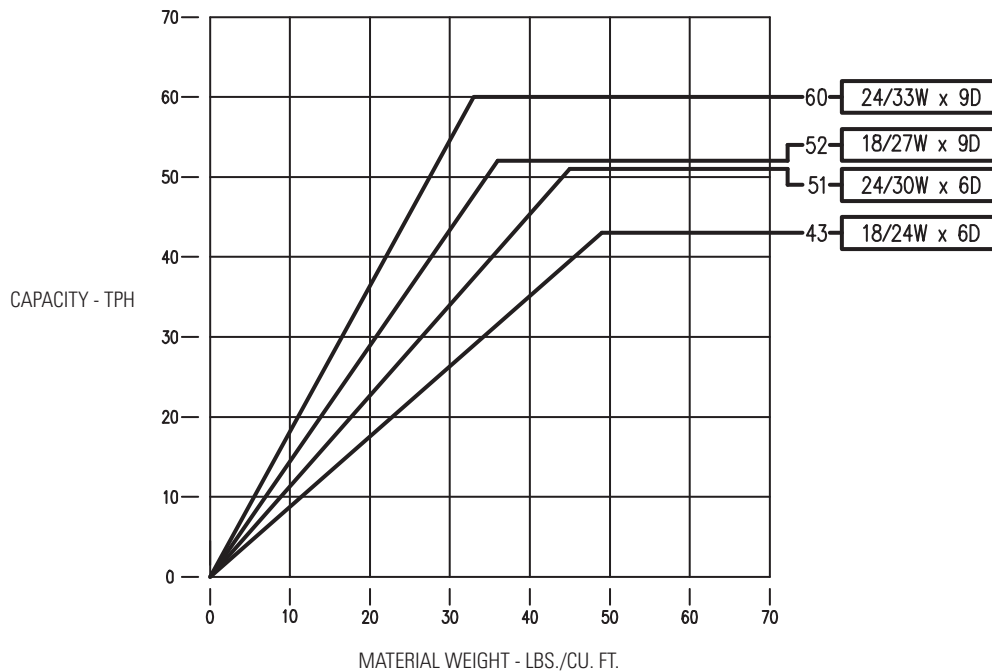



MODEL FSM CONVEYORS

For Medium-Duty Applications

Webster FSM vibrating conveyors are rugged, medium-duty models for small-particle sized material. Granular materials as fine as minus 100 mesh and lump materials up to any size that fits the pan can be conveyed. Their simplicity of design means little maintenance and low power requirements.

In addition to the standard sections shown on the following pages, other pan sizes and shapes, accessories and special features can be supplied.

DRIVE

Webster FSM vibrating conveyors are equipped with the P5000 positive eccentric drive and heavy-duty, self-aligning roller bearings.

DETAILS OF CONSTRUCTION

Pans for standard FSM vibrating conveyors are made

with flared sides, so the width is greater at the top than at the bottom. Standard pan bottom widths are 18" and 24". Standard pan thicknesses are $\frac{3}{16}$ " and $\frac{1}{4}$ ".

The base is a heavy formed-steel channel with the web on top. This style has no pockets on the topside to catch and hold foreign material. The base has anchor bolt pads welded on its underside so it contacts the foundation only where it is attached.

FSM CROSS SECTION DIMENSIONS

Pan Size	A	B	C	D*
18/24	18"	24"	6"	1'-6 $\frac{3}{4}$ "
18/27	18"	27"	9"	1'-9 $\frac{3}{4}$ "
24/30	24"	30"	6"	1'-6 $\frac{3}{4}$ "
24/33	24"	33"	9"	1'-9 $\frac{3}{4}$ "

* D Dimension – Add $\frac{1}{16}$ " for $\frac{1}{4}$ " thick pans.

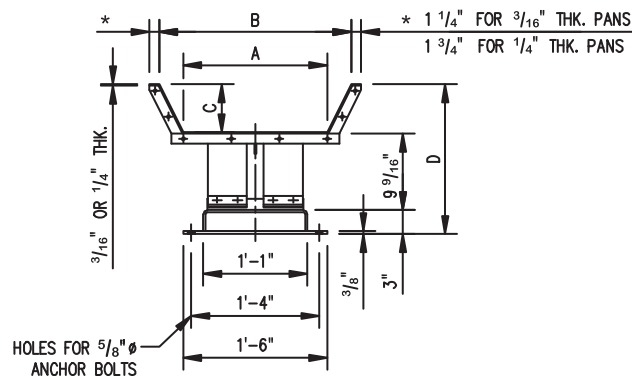

VIEW A-A

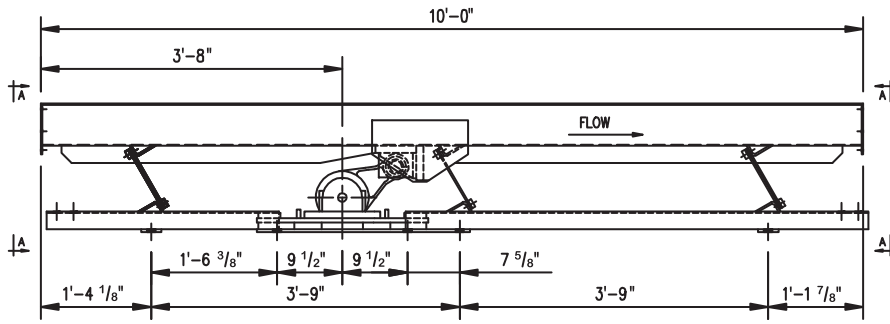

STANDARD DRIVE SECTION

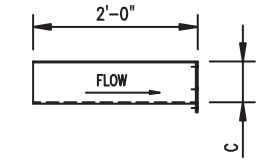

FEED END PAN ADDITION SECTION

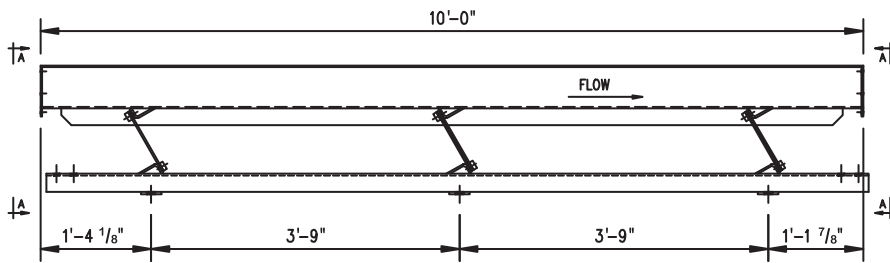

STANDARD EXTENSION SECTION

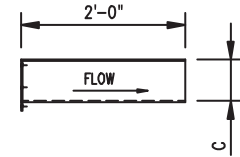

DISCHARGE END PAN ADDITION SECTION

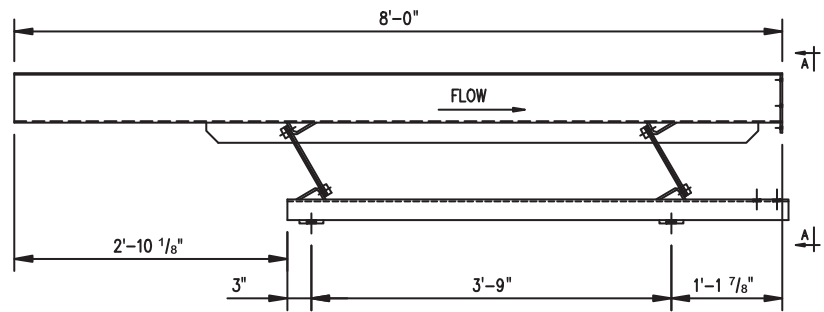
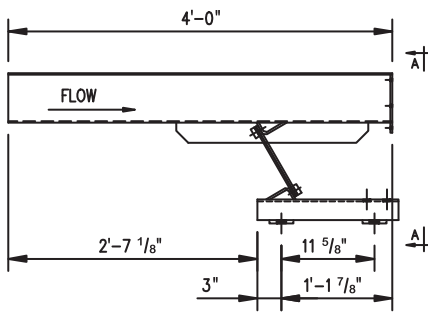

FEED END EXTENSION SECTIONS

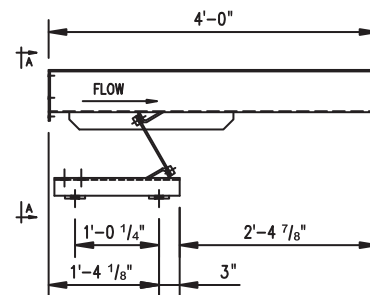
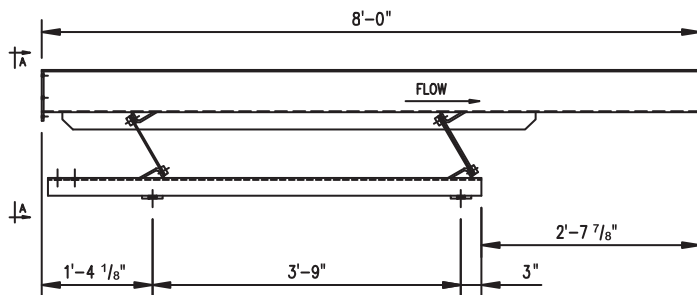

DISCHARGE END EXTENSION SECTIONS



MODEL FSM CONVEYORS

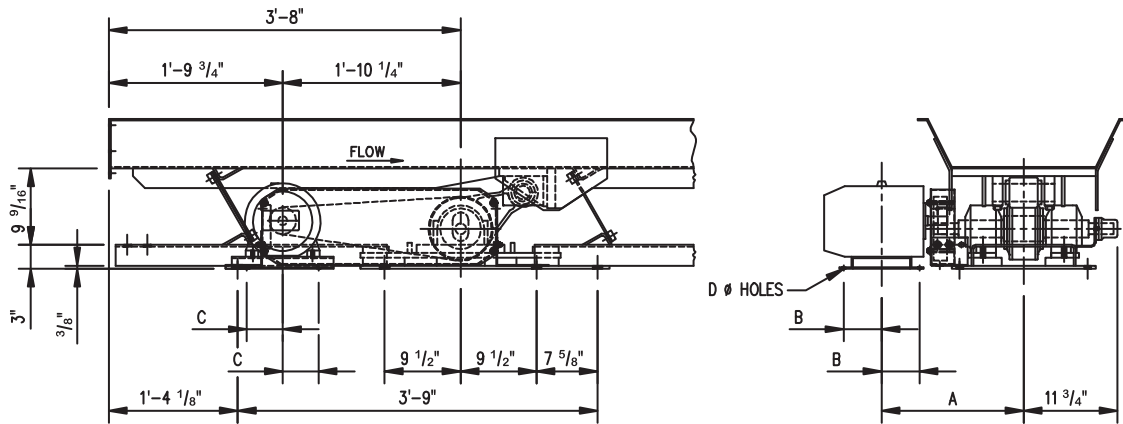

DRIVE ARRANGEMENT

Motor Size 1200 RPM	Frame No.	A	B	C	D
2 HP	184T	17 3/4"	4 3/4"	4 1/2"	1/2"
3 HP	213T	19"	4 3/4"	5 1/4"	1/2"
5 HP	215T	19 3/4"	5 1/2"	5 1/4"	1/2"
7 1/2 HP	254T	23"	6 5/8"	6 1/4"	5/8"
10 HP	256T	23 7/8"	7 1/2"	6 1/4"	5/8"

Motor may be assembled on either side of conveyor.



The motor size and capacity charts are based on a conveying speed of 50 FPM at $\frac{5}{8}$ " stroke and 550 RPM operating frequency. The nominal rated capacity of these standard-model Webster FSH vibrating conveyors is shown in the following chart.

CONVEYOR LENGTH AND MOTOR SIZE – NARROW BASE

Pan Size			Base Size	Stroke	Operating Frequency	Motor Size (1200 RPM)					
Width	Depth	Thk.				3 HP	5 HP	7½ HP	10 HP	15 HP	20 HP
18/24	6"	¼"	Narrow	⅝"	550 RPM	27'-0"	44'-0"	66'-0"	88'-0"	121'-0"	—
18/27	9"	¼"	Narrow	⅝"	550 RPM	23'-0"	38'-0"	57'-0"	76'-0"	104'-0"	134'-0"
18/30	12"	¼"	Narrow	⅝"	550 RPM	20'-0"	32'-0"	48'-0"	64'-0"	87'-0"	113'-0"
24/30	6"	⅝ ¹⁶ "	Narrow	⅝"	550 RPM	18'-0"	29'-0"	44'-0"	58'-0"	79'-0"	102'-0"
24/33	9"	⅝ ¹⁶ "	Narrow	⅝"	550 RPM	16'-0"	26'-0"	39'-0"	51'-0"	70'-0"	91'-0"
24/36	12"	⅝ ¹⁶ "	Narrow	⅝"	550 RPM	14'-0"	23'-0"	35'-0"	46'-0"	63'-0"	81'-0"

CAPACITY CHART

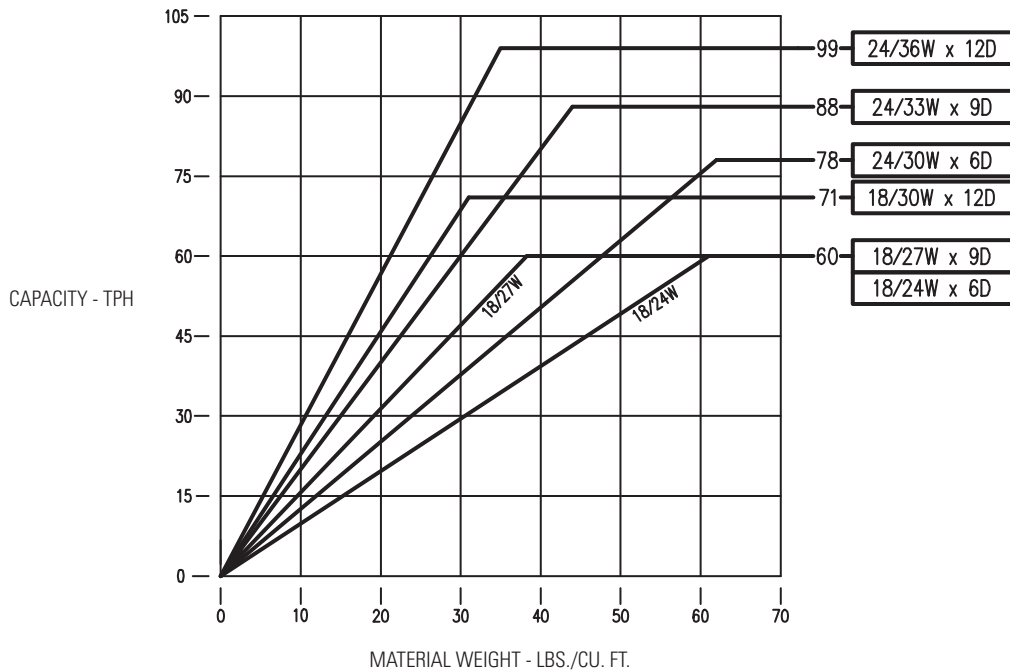



MODEL FSH SELECTION

The motor size and capacity charts are based on a conveying speed of 50 FPM at $\frac{5}{8}$ " stroke and 550 RPM operating frequency. The nominal rated capacity of these standard-model Webster FSH vibrating conveyors is shown in the following chart.

CONVEYOR LENGTH AND MOTOR SIZE – WIDE BASE

Pan Size			Base Size	Stroke	Operating Frequency	Motor Size (1200 RPM)					
Width	Depth	Thk.				3 HP	5 HP	7½ HP	10 HP	15 HP	20 HP
30/36	6"	$\frac{5}{16}$ "	Wide	$\frac{5}{8}$ "	550 RPM	13'-0"	23'-0"	36'-0"	48'-0"	67'-0"	87'-0"
30/39	9"	$\frac{5}{16}$ "	Wide	$\frac{5}{8}$ "	550 RPM	12'-0"	21'-0"	32'-0"	44'-0"	60'-0"	79'-0"
30/42	12"	$\frac{5}{16}$ "	Wide	$\frac{5}{8}$ "	550 RPM	11'-0"	18'-0"	29'-0"	39'-0"	54'-0"	71'-0"
36/42	6"	$\frac{5}{16}$ "	Wide	$\frac{5}{8}$ "	550 RPM	11'-0"	20'-0"	31'-0"	42'-0"	58'-0"	76'-0"
36/45	9"	$\frac{5}{16}$ "	Wide	$\frac{5}{8}$ "	550 RPM	10'-0"	18'-0"	28'-0"	38'-0"	53'-0"	69'-0"
36/48	12"	$\frac{5}{16}$ "	Wide	$\frac{5}{8}$ "	550 RPM	9'-0"	16'-0"	26'-0"	35'-0"	49'-0"	63'-0"

CAPACITY CHART

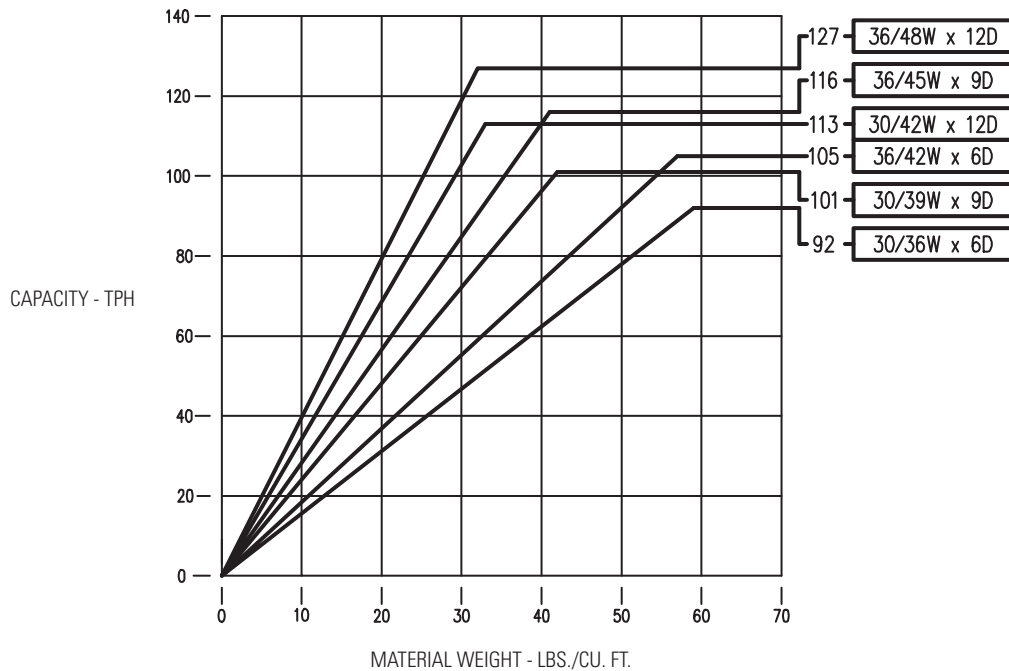



For Heavy Duty Applications

Webster FSH vibrating conveyors are heavy duty models for applications with larger particle size and increased capacities. FSH models can handle large amounts of heavy, abrasive materials, such as sand, castings and scrap.

In addition to the standard sections shown on the following pages, other pan sizes, accessories and special features can be supplied.

DRIVE

Webster FSH vibrating conveyors are equipped with the P8000 positive eccentric drive and heavy duty, self-aligning roller bearings.

DETAILS OF CONSTRUCTION

Pans for standard FSH vibrating conveyors are made with

flared sides, so the width is greater at the top than at the bottom. Standard pan bottom widths are 18", 24", 30" and 36". Standard pan thickness is $\frac{1}{4}$ " for the 18" nonexpansion type and $\frac{5}{16}$ " for all others.

The base is a pair of rolled steel channels. Anchor bolt pads are welded on the underside so the base contacts the foundation only where it is attached.

Pan Size	A	B	C	D	Base
18/24	18"	24"	6"	1'-11 $\frac{15}{16}$ "	Narrow
18/27	18"	27"	9"	2'-2 $\frac{15}{16}$ "	Narrow
18/30	18"	30"	12"	2'-5 $\frac{15}{16}$ "	Narrow
24/30	24"	30"	6"	2'-0"	Narrow
24/33	24"	33"	9"	2'-3"	Narrow
24/36	24"	36"	12"	2'-6"	Narrow
30/36	30"	36"	6"	2'-0"	Wide
30/39	30"	39"	9"	2'-3"	Wide
30/42	30"	42"	12"	2'-6"	Wide
36/42	36"	42"	6"	2'-0"	Wide
36/45	36"	45"	9"	2'-3"	Wide
36/48	36"	48"	12"	2'-6"	Wide

* D Dimensions $\frac{1}{4}$ " thick for 18" bottom and $\frac{5}{16}$ " thick for all others.

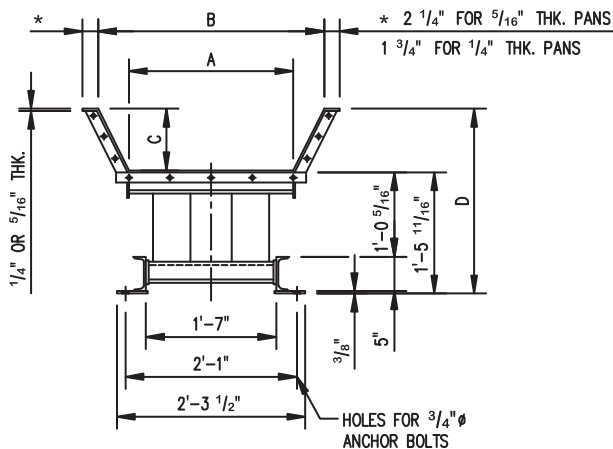

VIEW A-A

NARROW BASE

PAN BOTTOM 18" MIN. TO 24" MAX.

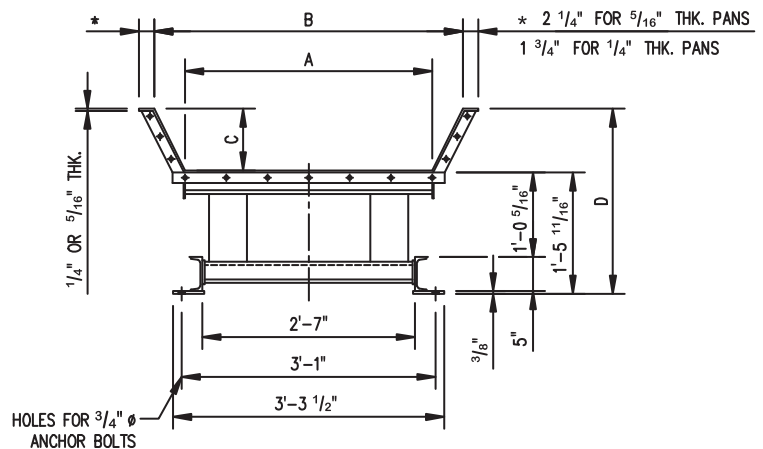

VIEW A-A

WIDE BASE

PAN BOTTOM 30" MIN. TO 36" MAX.



MODEL FSH CONVEYORS

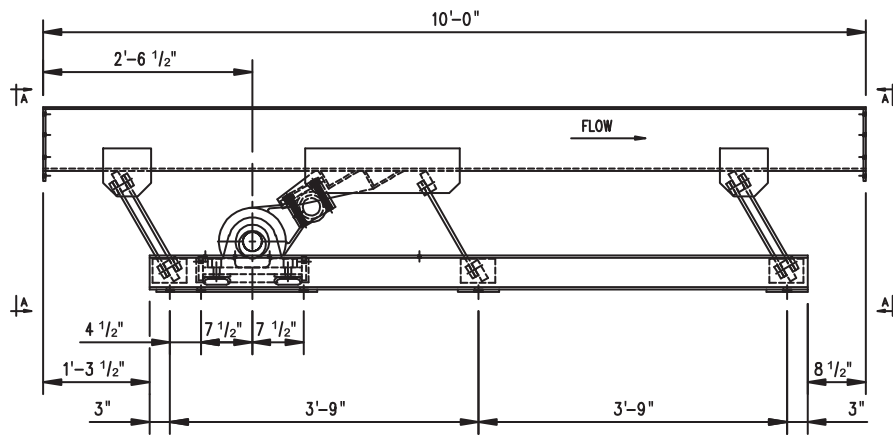

STANDARD DRIVE SECTION

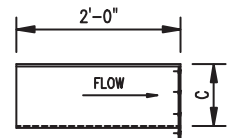

FEED END PAN ADDITION SECTION

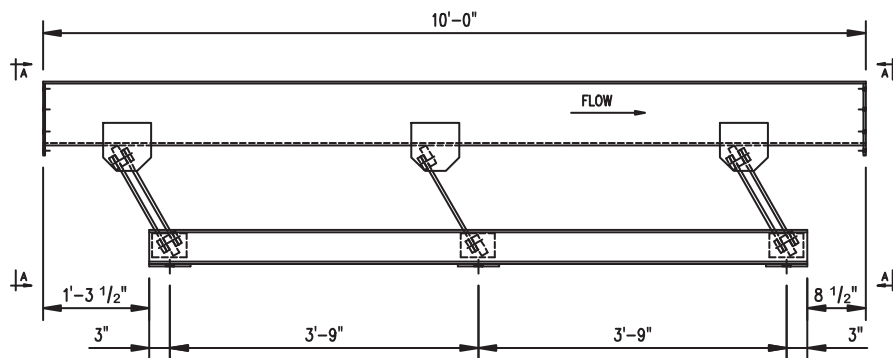

STANDARD EXTENSION SECTION

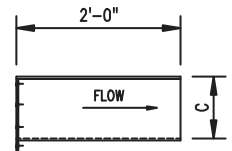

DISCHARGE END PAN ADDITION SECTION

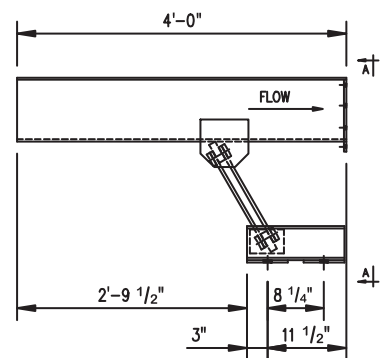
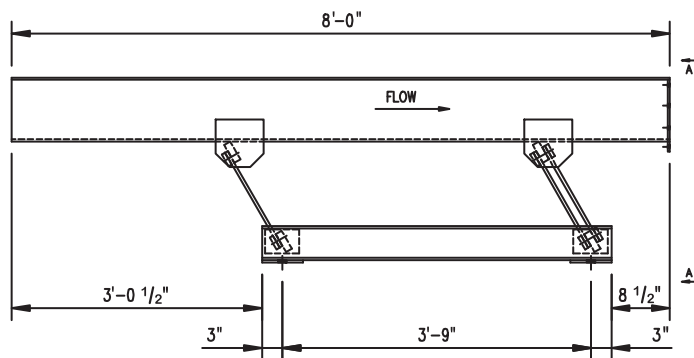

FEED END EXTENSION SECTIONS

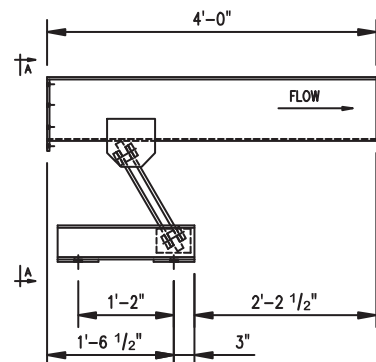
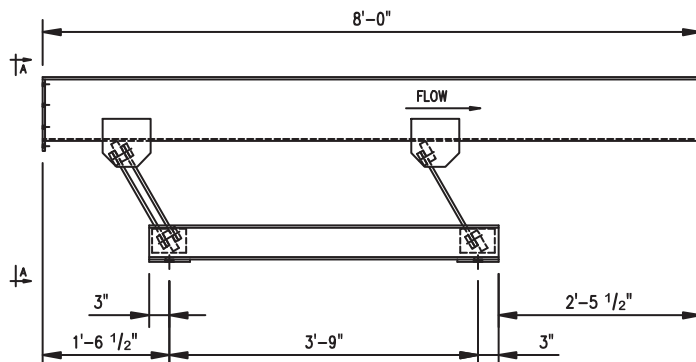

DISCHARGE END EXTENSION SECTIONS

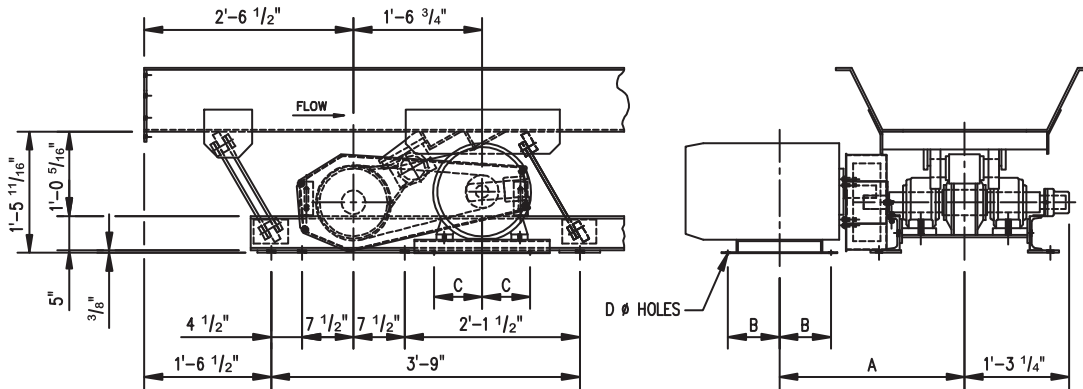

DRIVE ARRANGEMENT – NARROW BASE CONVEYOR

Motor Size 1200 RPM	Frame No.	A	B	C	D
3 HP	213T	22 1/8"	4 3/4"	5 1/4"	1/2"
5 HP	215T	22 7/8"	5 1/2"	5 1/4"	1/2"
7 1/2 HP	254T	24 3/8"	6 5/8"	6 1/4"	5/8"
10 HP	256T	25 1/4"	7 1/2"	6 1/4"	5/8"
15 HP	284T	27"	7 1/2"	7"	5/8"
20 HP	286T	28"	8 1/4"	7"	5/8"

Motor may be assembled on either side of conveyor.

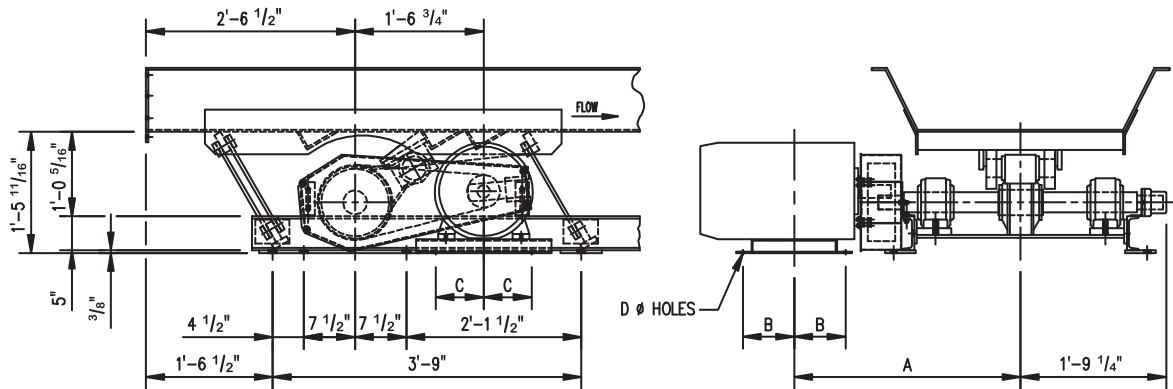

DRIVE ARRANGEMENT – WIDE BASE CONVEYOR

Motor Size 1200 RPM	Frame No.	A	B	C	D
3 HP	213T	28 1/8"	4 3/4"	5 1/4"	1/2"
5 HP	215T	28 7/8"	5 1/2"	5 1/4"	1/2"
7 1/2 HP	254T	30 3/8"	6 5/8"	6 1/4"	5/8"
10 HP	256T	31 1/4"	7 1/2"	6 1/4"	5/8"
15 HP	284T	33"	7 1/2"	7"	5/8"
20 HP	286T	34"	8 1/4"	7"	5/8"

Motor may be assembled on either side of conveyor.



COILWEB® SERIES VIBRATING CONVEYORS

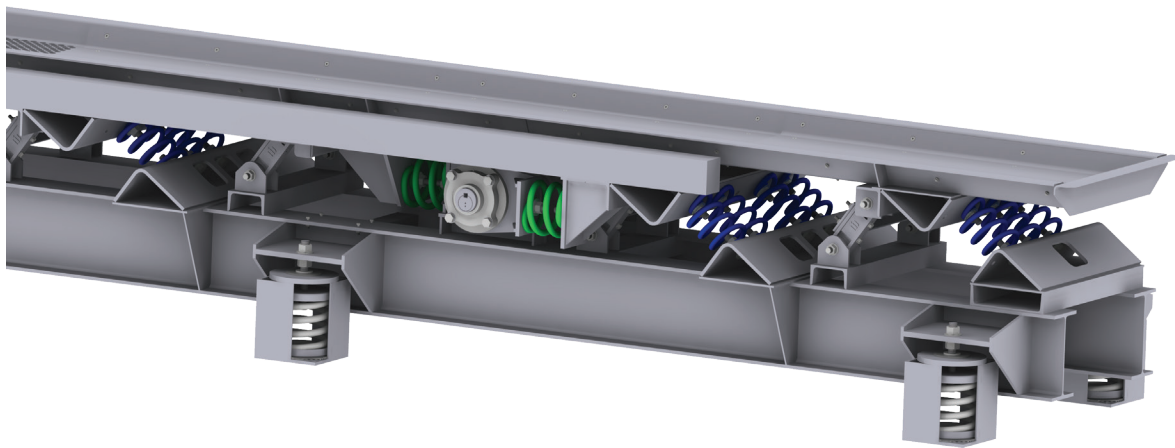

This series of heavy duty service conveyors includes the CoilWeb® and CoilWeb® LS models, both with a broad range of capabilities for tough conveying applications. Features of the CoilWeb® series include use of the natural frequency principle utilizing coil springs, controlled vibration, semipositive coil spring drive and standardized spring and rocker arm components. They provide a heavy-duty solution for rigorous bulk material handling and processing jobs.

CoilWeb® vibrating conveyors will convey granular or lump materials ranging in size from minus 100 mesh to any lump size which will fit into the pan. These conveyors can

handle density ranging from several pounds to several hundred pounds per cubic foot. CoilWeb® is designed for heavily loaded hot or abrasive material applications which are not readily handled by other conveyors. CoilWeb® conveyors may also be adapted for processing operations, such as screening, sorting, washing, dewatering, cooling or drying.

The following pages detail standard pan size and capacity information. Other pan sizes and shapes are available. CoilWeb® series vibrating conveyors can be custom-designed for your application.

MATERIAL

CoilWeb® series vibrating conveyors incorporate fabricated steel pans, a natural frequency spring system, a semipositive eccentric drive powered by an electric motor and v-belts on a fabricated steel base.

ASSEMBLY

Standard drive and extension sections are delivered in preassembled sections. Standard welded pan joints or jig-fixtured, bolted pan flanges are available for joining the sections together.

APPLICATION

CoilWeb® series vibrating conveyors are used where horizontal or shallow incline conveying is required. They handle a wide variety of bulk materials, from powders to solids. They are designed to handle fragile, sharp and irregularly shaped materials and are primarily used in the forest products, stamping, food, grain, foundry and die cast industries.



SPRING ASSEMBLIES

The coil springs used in the CoilWeb® series vibrating conveyors are fabricated of alloy steel. Each spring assembly location includes rocker arms to control the direction of vibration, and rubber bushings are located at both ends of a malleable iron rocker arm for a nonlubricated joint. This super-duty design of coil spring assemblies, along with heavy duty pan construction, is built to operate in harsh environments and heavy material loading, providing long service life with minimal maintenance.

COIL SPRING DRIVE

CoilWeb® series vibrating conveyors feature a semipositive drive. These drives are equipped with heavy-duty, self-aligning roller bearing pillow blocks, heavy-duty flange mount connecting rod bearings, and a coil drive spring pan connection. The incorporation of the drive springs substantially lowers the starting and full-load torque requirements, resulting in dramatic horsepower reduction over a positive connected drive.

Once a conveyor reaches its operating speed, very little drive force is required, due to the pan spring system's resonant frequency. This results in very little relative deflection between the connecting rod and the drive spring system. This design substantially reduces torque and horsepower requirements.

UNBALANCED OR BALANCED CONSTRUCTION

The standard unbalanced CoilWeb® series vibrating conveyors develop a dynamic reaction and must be installed on an appropriate foundation or support structure, which is usually at or below ground level. For installations requiring a minimum transmission of the dynamic reaction to supports, a selection of balanced, isolated or balanced/isolated construction is available.

In balanced construction, a balancer is driven 180° out of phase to the pan. This balancer is equal in mass to the pan and has a duplicate reactor spring assembly system. Being 180° out of phase results in two equal and opposite dynamic reactions that cancel out 80% to 95% of the dynamic reaction to the supports.

In isolated construction, a relatively short-length CoilWeb® vibrating conveyor is equipped with a heavy moving inertia base and is mounted to the support structure on soft isolation springs. This type of construction, which is less complex than balancing, reduces the reaction forces by 85% to 95%.

A combination of balanced/isolated construction can be utilized to provide the maximum dampening of the dynamic reaction.

STANDARD AND HIGH-TEMPERATURE HEAVY-DUTY CONSTRUCTION

Webster CoilWeb® series vibrating conveyors are also available in two construction types, depending on the temperature of the material being conveyed. Standard construction is used when material temperature is no higher than 200° F. For hotter materials, heat expansion construction is used. The heat expansion type is designed to allow the pan to expand or contract independently from the reactor spring and drive systems. The heat expansion pan is also designed to reduce heat conduction to the spring and drive systems.

ACCESSORIES

A wide range of optional features are available for use with CoilWeb® vibrating conveyors, including covers; side or bottom discharges; intermediate discharges with gates; pans with multiple compartments or channels; screen sections; nonmagnetic pan sections for use with magnetic separators; nonmetallic pan sections for use with metal detectors; steel pan liners for impact or abrasion resistance; rubber pan liners for wear resistance or noise reduction; and special discharges for feeding process equipment and steel support structures.



MODEL COILWEB® SELECTION

The motor size and capacity charts are based on a conveying speed of 50 FPM at $\frac{7}{8}$ " stroke and 420 RPM operating frequency. The nominal rated capacity of these standard-model Webster CoilWeb® vibrating conveyors is shown in the following chart.

UNBALANCED CONVEYOR LENGTH AND MOTOR SIZE

Pan Size			Stroke	Operating Frequency	Motor Size (1200 RPM)				
Width	Depth	Thk.			1½ HP	2 HP	3 HP	5 HP	7½ HP
18/24	6"	¼"	$\frac{7}{8}$ "	420 RPM	29'-0"	34'-0"	66'-0"	103'-0"	116'-0"
18/27	9"	¼"	$\frac{7}{8}$ "	420 RPM	26'-0"	31'-0"	59'-0"	93'-0"	114'-0"
18/30	12"	¼"	$\frac{7}{8}$ "	420 RPM	22'-0"	26'-0"	51'-0"	80'-0"	103'-0"
24/30	6"	¼"	$\frac{7}{8}$ "	420 RPM	24'-0"	29'-0"	57'-0"	89'-0"	112'-0"
24/33	9"	¼"	$\frac{7}{8}$ "	420 RPM	21'-0"	26'-0"	50'-0"	79'-0"	100'-0"
24/36	12"	¼"	$\frac{7}{8}$ "	420 RPM	19'-0"	23'-0"	45'-0"	72'-0"	91'-0"

CAPACITY CHART

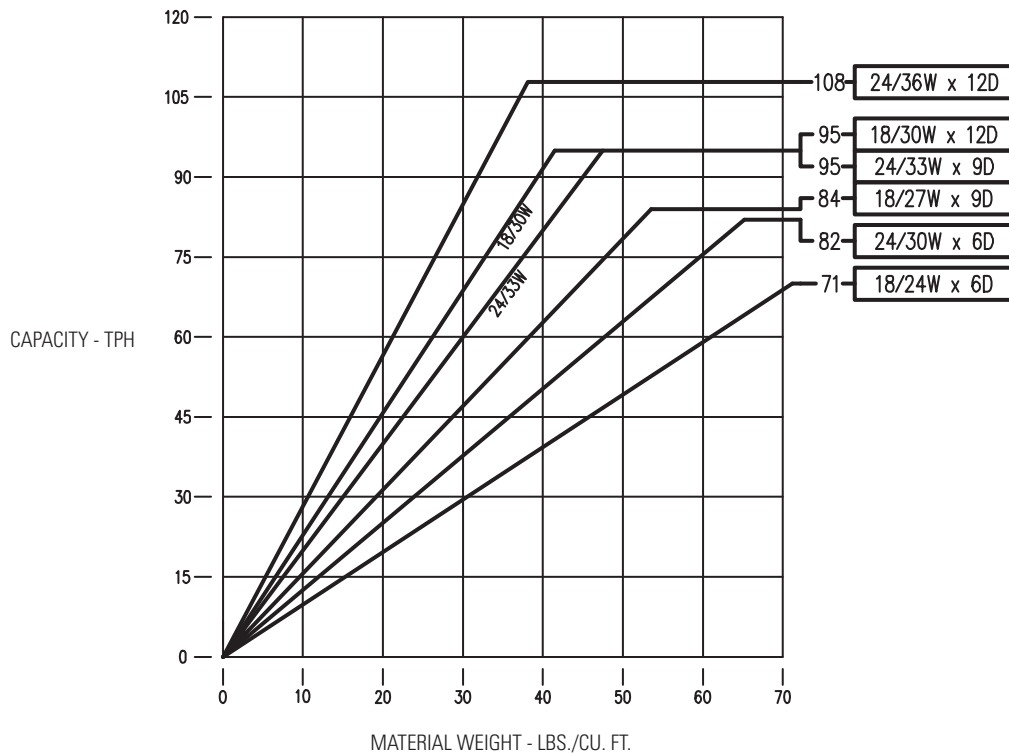



For Heavy Duty Applications

DETAILS OF CONSTRUCTION

Pans for standard CoilWeb® and CoilWeb® LS vibrating conveyors are made with flared sides, so the width at the top is greater than at the bottom. Standard pan bottom widths are in 6" increments from 18" to 48" wide. Standard pan thicknesses are 1/4", 5/16" and 3/8", depending on the application. The spring pads are a heavy fabricated angle

weldment. Other sizes, including wider pans, are available.

The standard base is made of heavy rolled structural channel with cross members welded in place at the spring pads and rocker arms. Anchor pads may be welded under the base channel by the customer, allowing the base to contact an uneven foundation only at points of attachment.

COILWEB® UNBALANCED CROSS SECTION DIMENSIONS

Pan Size	A	B	C	D
18/24	18"	24"	6"	2'-1"
18/27	18"	27"	9"	2'-1"
18/30	18"	30"	12"	2'-1"
24/30	24"	30"	9"	2'-7"
24/33	24"	33"	9"	2'-7"
24/36	24"	36"	12"	2'-7"

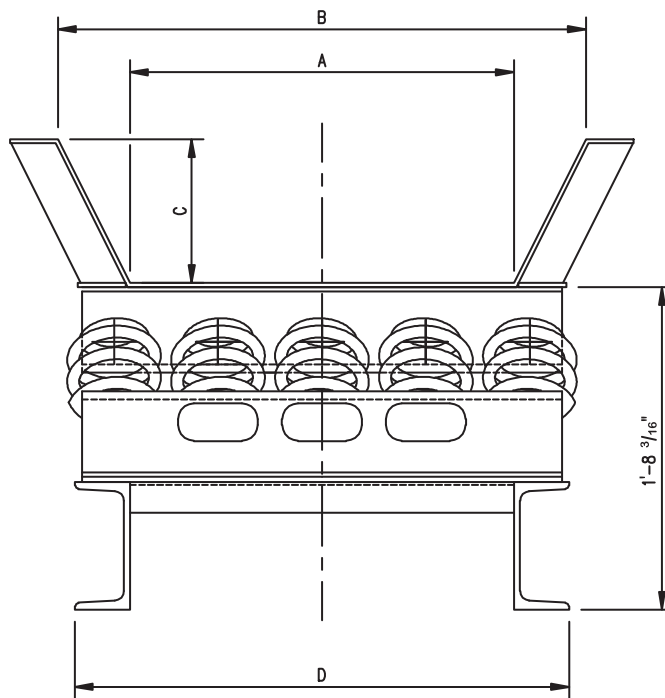

COILWEB® UNBALANCED



MODEL COILWEB® LS SELECTION (UNBALANCED)

The motor size and capacity charts are based on a conveying speed of 50 FPM at $\frac{7}{8}$ " stroke and 420 RPM operating frequency. The nominal rated capacity of these standard-model Webster CoilWeb® LS vibrating conveyors is shown in the following charts.

UNBALANCED CONVEYOR LENGTH AND MOTOR SIZE

Pan Size			Stroke	Operating Frequency	Motor Size (1200 RPM)					
Width	Depth	Thk.			3 HP	5 HP	7½ HP	10 HP	15 HP	20 HP
24/30	6"	$\frac{3}{8}$ "	$\frac{7}{8}$ "	420 RPM	44'-0"	64'-0"	91'-0"	130'-0"	—	—
24/33	9"	$\frac{3}{8}$ "	$\frac{7}{8}$ "	420 RPM	39'-0"	57'-0"	80'-0"	116'-0"	—	—
24/36	12"	$\frac{3}{8}$ "	$\frac{7}{8}$ "	420 RPM	35'-0"	51'-0"	72'-0"	104'-0"	—	—
30/36	6"	$\frac{3}{8}$ "	$\frac{7}{8}$ "	420 RPM	38'-0"	55'-0"	78'-0"	113'-0"	—	—
30/39	9"	$\frac{3}{8}$ "	$\frac{7}{8}$ "	420 RPM	34'-0"	49'-0"	70'-0"	101'-0"	—	—
30/42	12"	$\frac{3}{8}$ "	$\frac{7}{8}$ "	420 RPM	31'-0"	45'-0"	63'-0"	92'-0"	—	—
36/42	6"	$\frac{3}{8}$ "	$\frac{7}{8}$ "	420 RPM	33'-0"	48'-0"	69'-0"	99'-0"	145'-0"	175'-0"
36/45	9"	$\frac{3}{8}$ "	$\frac{7}{8}$ "	420 RPM	30'-0"	44'-0"	62'-0"	90'-0"	132'-0"	162'-0"
36/48	12"	$\frac{3}{8}$ "	$\frac{7}{8}$ "	420 RPM	27'-0"	40'-0"	57'-0"	83'-0"	121'-0"	145'-0"

CAPACITY CHART

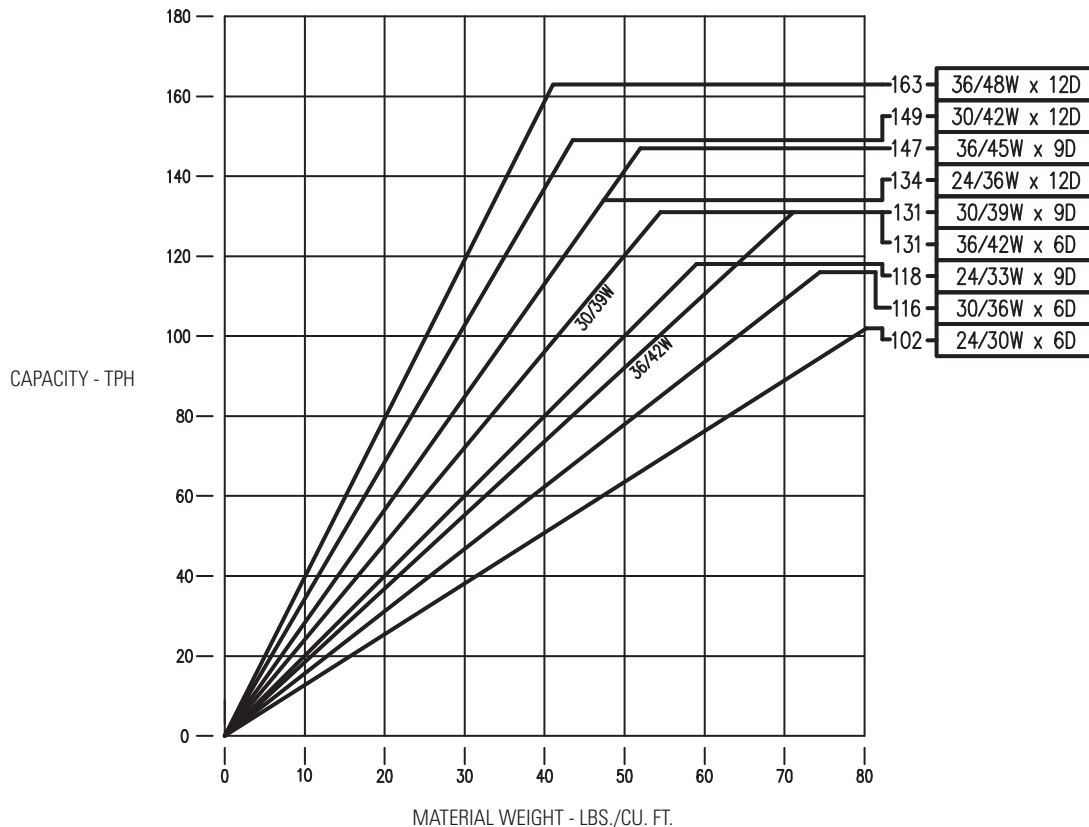



The motor size and capacity charts are based on a conveying speed of 50 FPM at $7\frac{7}{8}$ " stroke and 420 RPM operating frequency. The nominal rated capacity of these standard-model Webster CoilWeb® LS vibrating conveyors is shown in the following charts.

BALANCED CONVEYOR LENGTH AND MOTOR SIZE

Pan Size			Stroke	Operating Frequency	Motor Size (1200 RPM)				
Width	Depth	Thk.			5 HP	7½ HP	10 HP	15 HP	20 HP
24/30	6"	¼"	7⅞"	420 RPM	42'-0"	61'-0"	89'-0"	126'-0"	145'-0"
24/33	9"	¼"	7⅞"	420 RPM	38'-0"	54'-0"	79'-0"	112'-0"	129'-0"
24/36	12"	¼"	7⅞"	420 RPM	34'-0"	49'-0"	71'-0"	101'-0"	116'-0"
30/36	6"	¼"	7⅞"	420 RPM	36'-0"	52'-0"	76'-0"	108'-0"	127'-0"
30/39	9"	¼"	7⅞"	420 RPM	33'-0"	47'-0"	69'-0"	97'-0"	114'-0"
30/42	12"	¼"	7⅞"	420 RPM	30'-0"	43'-0"	62'-0"	89'-0"	103'-0"
36/42	6"	¼"	7⅞"	420 RPM	32'-0"	46'-0"	67'-0"	95'-0"	112'-0"
36/45	9"	¼"	7⅞"	420 RPM	29'-0"	42'-0"	61'-0"	86'-0"	102'-0"
36/48	12"	¼"	7⅞"	420 RPM	26'-0"	38'-0"	56'-0"	80'-0"	93'-0"

CAPACITY CHART

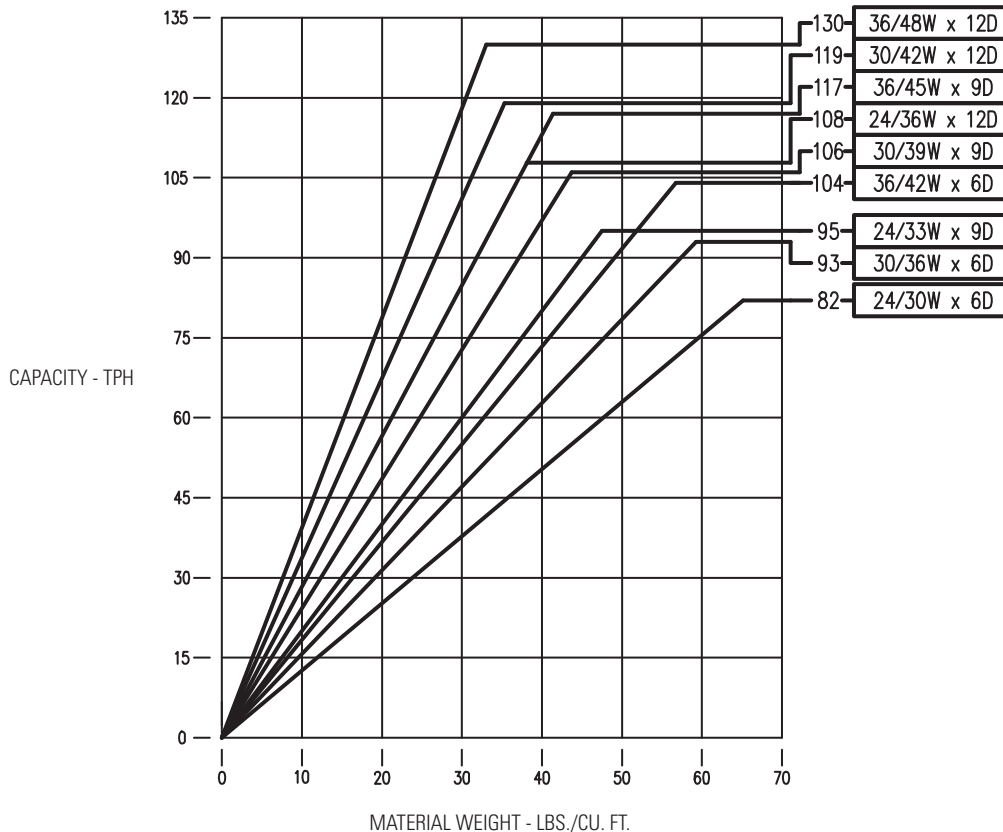



MODEL COILWEB® LS CONVEYORS (UNBALANCED)

COILWEB® LS UNBALANCED CROSS SECTION DIMENSIONS

Pan Size	A	B	C	D
24/30	24"	30"	6"	2'-7"
24/33	24"	33"	9"	2'-7"
24/36	24"	36"	12"	2'-7"
30/36	30"	36"	6"	3'-1"
30/39	30"	39"	9"	3'-1"
30/42	30"	42"	12"	3'-1"
36/42	36"	42"	6"	3'-7"
36/45	36"	45"	9"	3'-7"
36/48	36"	48"	12"	3'-7"

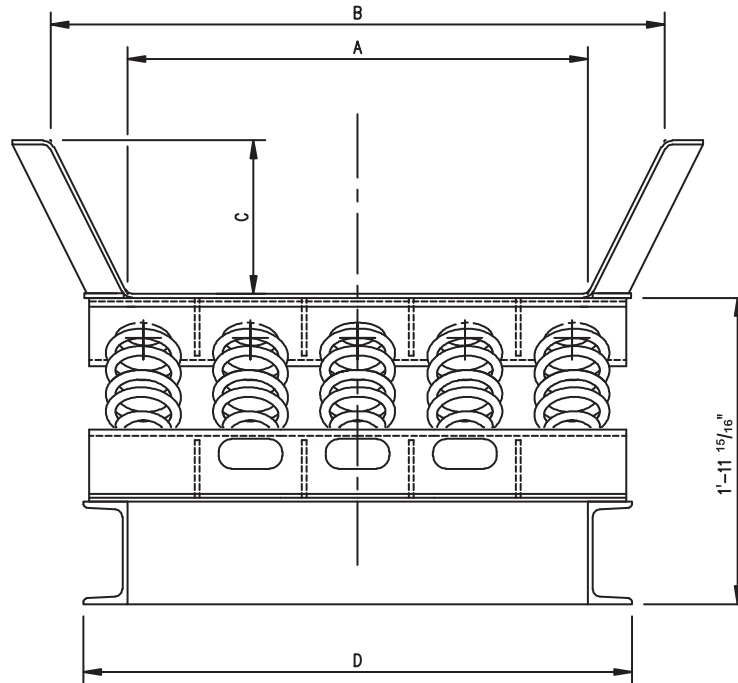

COILWEB® LS UNBALANCED

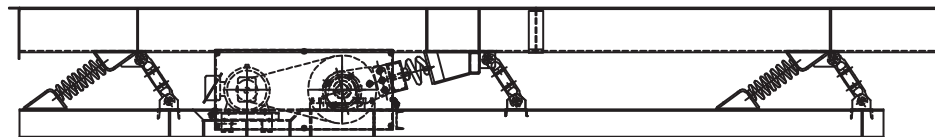

TYPICAL COILWEB® LS ELEVATION



COILWEB® LS BALANCED CROSS SECTION DIMENSIONS

Pan Size	A	B	C	D
24/30	24"	30"	6"	3'-7"
24/33	24"	33"	9"	3'-7"
24/36	24"	36"	12"	3'-7"
30/36	30"	36"	6"	4'-1"
30/39	30"	39"	9"	4'-1"
30/42	30"	42"	12"	4'-1"
36/42	36"	42"	6"	4'-7"
36/45	36"	45"	9"	4'-7"
36/48	36"	48"	12"	4'-7"

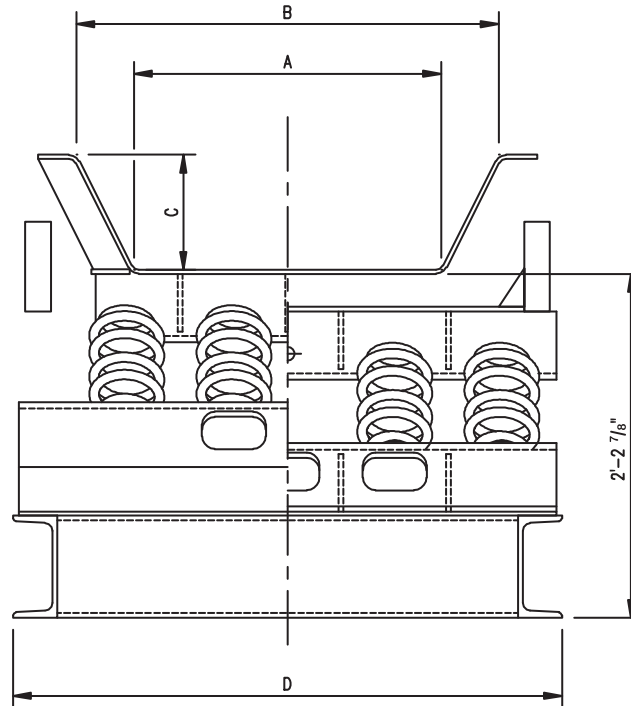

COILWEB® LS BALANCED

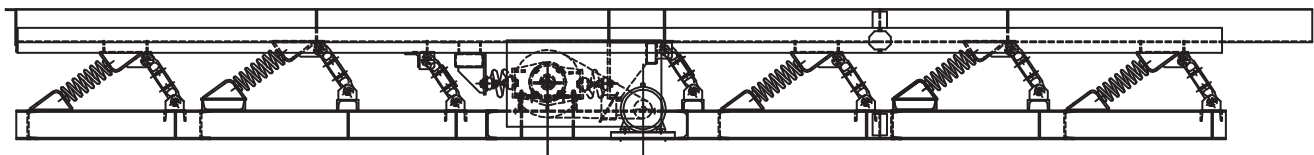

COILWEB® LS BALANCED ELEVATION



MODEL COILWEB® LS CONVEYORS

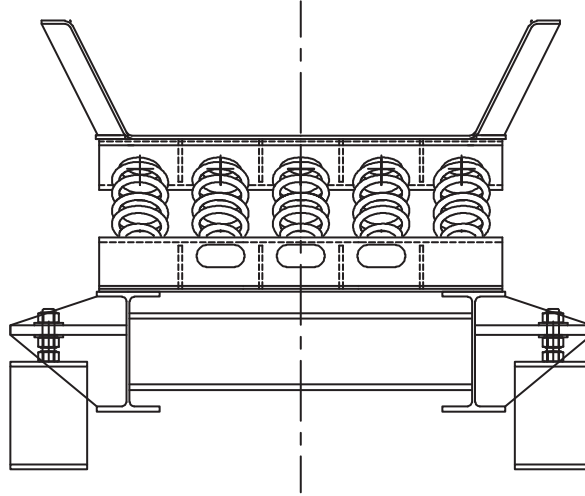

TYPICAL COILWEB® LS ISOLATED CROSS SECTION

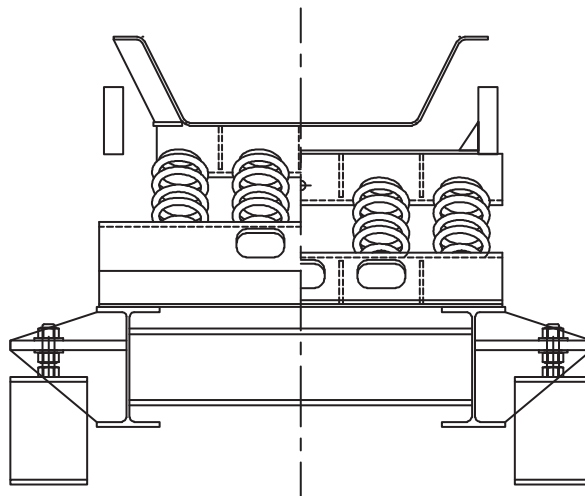

TYPICAL COILWEB® LS BALANCED/ISOLATED CROSS SECTION



THE WEBSTER VALUE

For over 145 years, Webster has provided conveying solutions to a diverse range of markets with our extensive variety of products and industry expertise. A key to our success is making a difference through industry, work, self, family and community.



AMERICAN MATERIALS, AMERICAN LABOR & AMERICAN PRIDE

Webster's reputation for high-quality products originates from the same principles they were founded on in 1876. Our Made in the USA brand is demonstrated through our domestic supply chain partners and our American workforce.



VERTICALLY INTEGRATED MANUFACTURING FACILITY

While companies are relying increasingly on outsourcing for production needs, Webster has invested in building, maintaining and growing a vertically integrated manufacturing system.



WORLD CLASS CUSTOMER SUPPORT & DELIVERIES

Providing value to customers is Webster's top priority. Our commitment and responsiveness to customers, industry best deliveries and our engineered solutions are what set us apart from the competition.



SUPERIOR QUALITY & INNOVATION

Webster's strict manufacturing, ISO quality standards and continuous innovation ensure that we are providing our customers with the highest quality products in the industry.

ESTABLISHED 1876